

# Notes to Part 1

## Compliance

**A-1.1.1.1.(3) Factory-Constructed Buildings.** The Building By-law applies the same requirements to site-built and factory-constructed buildings. However, it can often be difficult to determine whether a factory-constructed building complies with the By-law once it has been delivered to the construction site because many of the wall, roof and floor assemblies are closed in and so their components cannot be inspected. CSA A277, “Procedure for Factory Certification of Buildings,” was developed to address this problem with regard to residential, commercial and industrial buildings. This standard describes a procedure whereby an independent certification agency can review the quality control procedures of a factory and make periodic unannounced inspections of its products. The standard is not a building code, only a procedure for certifying compliance of factory-constructed components with a building code or other standard. If a factory-constructed building bears the label of an accredited certification agency indicating that compliance with the National Building Code has been certified using the CSA A277 procedure, the accepting authority will have some assurance that the concealed components do not require re-inspection on site.

On the other hand, standards in the CSA Z240 MH Series, “Manufactured Homes,” do resemble a building code. These portions contain requirements in many of the areas where the Building By-law also has requirements and frequently the requirements are different. Other portions of these requirements are different. Other portions of the Z240 standards deal with special requirements for manufactured homes related to the fact that these houses must be moved over roads, which is an issue the Building By-law does not address. The Building By-law considers mobile homes certified to the Z240 standard as acceptable housing and they are permitted under Clause 1.1.1.1.(2)(g).

The Building By-law does reference CSA Z240.10.1, “Site Preparation, Foundation, and Anchorage of Manufactured Homes,” which is not actually part of the CSA Z240 MH Series. This standard contains requirements for surface foundations where buildings – not just houses – comply with the deformation resistance test provided in CSA Z240.2.1, “Structural Requirements for Manufactured Homes.”

**A-1.1.1.1.(5) Heritage Buildings.** The City has identified conservation of selected heritage properties, or protection of the heritage character of certain areas, as being community planning objectives. The City’s planning objectives and growth strategy encourage and support the retention of these properties and ways to make restoration and rehabilitation of heritage buildings economically viable for the properties’ owners.

It is generally recognized that the present Building By-law was primarily written for new construction and provides for a performance level that is significantly higher than what exists with many older buildings. To apply present By-law provisions to existing buildings is, in many cases, impractical and with heritage buildings may compromise historic appearances or authenticity. Therefore, Section 11.5 was developed to provide alternate methods for complying with the performance level intended by the By-law. The use of sprinklers is advocated as one of the primary methods in assuring this performance level for heritage buildings. Sprinkler systems not only control the fire, which aids evacuation, but also provides the added benefit of protecting the building from possible destruction by fire.

Section 11.5. represents some of the ways that restoration and rehabilitation of heritage buildings can be facilitated without compromising the objectives of the By-law.

Only buildings which have been identified by the provincial or a local government are included in the definition of “heritage building.” However, subject to the discretion of the Chief Building Official, buildings with character merit may also qualify under Section 3 of the Heritage By-law. For these buildings, conservation is also a public objective. Heritage buildings often offer unique problems and opportunities, and each situation must be assessed individually.

The use of the Alternate Compliance Methods in Table A-1.1.1.5. is not mandatory, and an owner may choose

- to apply acceptable solutions in Division B,
- to apply alternate solutions under Clause 1.2.1.1.(1)(b),
- to apply alternate compliance methods in Table A-1.1.1.5., or
- to combine these options.

**A-1.1.1.2.(1) Application to Existing Buildings.** This By-law is most often applied to existing or relocated buildings when an owner wishes to rehabilitate a building, change its use, or build an addition, or when an enforcement authority decrees that a building or class of buildings be altered for reasons of public safety. It is not intended that the Building By-law be used to enforce the retrospective application of new requirements to existing buildings or existing portions of relocated buildings, unless specifically required by local regulations or bylaws. For example, although the Fire By-law could be interpreted to require the installation of fire alarm, standpipe and hose, and automatic sprinkler systems in an existing building for which there were no requirements at

the time of construction, it is not intended that the Fire By-law be applied in this manner to these buildings unless the authority having jurisdiction has determined that there is an inherent threat to occupant safety and has issued an order to eliminate the unsafe condition, or where substantial changes or additions are being made to an existing building or the occupancy has been changed. (See also Note A-1.1.1.1.(1) of Division A of the Fire By-law.)

Relocated buildings that have been in use in another location for a number of years can be considered as existing buildings, in part, and the same analytical process can be applied as for existing buildings. It should be noted, however, that a change in occupancy may affect some requirements (e.g. loads and fire separations) and relocation to an area with different wind, snow or earthquake loads will require the application of current By-law requirements. Depending on the construction of the building and the changes in load, structural modifications may be required. Similarly, parts of a relocated or existing building that are reconstructed, such as foundations and basements, or parts being modified are required to be built to current codes.

Whatever the reason, By-law application to existing or relocated buildings requires careful consideration of the level of safety needed for that building. This consideration involves an analytical process similar to that required to assess alternative design proposals for new construction. See Clause 1.2.1.1.(1)(b) for information on achieving compliance with the By-law using alternative solutions.

In developing By-law requirements for new buildings, consideration has been given to the cost they impose on a design in relation to the perceived benefits in terms of safety. The former is definable; the latter difficult to establish on a quantitative basis. In applying the By-law requirements to an existing building, the benefits derived are the same as in new buildings. On the other hand, the increased cost of implementing in an existing building a design solution that would normally be intended for a new building may be prohibitive.

The successful application of By-law requirements to existing construction becomes a matter of balancing the cost of implementing a requirement with the relative importance of that requirement to the overall By-law objectives. The degree to which any particular requirement can be relaxed without affecting the intended level of safety of the By-law requires considerable judgment on the part of both the designer and the authority having jurisdiction.

Further information on the application of By-law requirements to existing or relocated buildings can be found in the following publications:

- “User’s Guide – NBC 1995, Fire Protection, Occupant Safety and Accessibility (Part 3)”
- “Guidelines for Application of Part 3 of the National Building Code of Canada to Existing Buildings”
- Commentary entitled “Application of NBC Part 4 of Division B for the Structural Evaluation and Upgrading of Existing Buildings” of the “User’s Guide – NBC 2015, Structural Commentaries (Part 4 of Division B)”
- “User’s Guide – NBC 1995, Application of Part 9 to Existing Buildings”
- CBD 230, “Applying Building Codes to Existing Buildings”

These publications can be ordered through NRC’s Web site.

**A-1.2.1.1.(1)(a) By-law Compliance via Acceptable Solutions.** If a building design (e.g. material, component, assembly or system) can be shown to meet all provisions of the applicable acceptable solutions in Division B (e.g. it complies with the applicable provisions of a referenced standard), it is deemed to have satisfied the objectives and functional statements linked to those provisions and thus to have complied with that part of the By-law. In fact, if it can be determined that a design meets all the applicable acceptable solutions in Division B, there is no need to consult the objectives and functional statements in Division A to determine its compliance.

**A-1.2.1.1.(1)(b) By-law Compliance via Alternative Solutions.** Where a design differs from the acceptable solutions in Division B, then it should be treated as an “alternative solution.” A proponent of an alternative solution must demonstrate that the alternative solution addresses the same issues as the applicable acceptable solutions in Division B and their attributed objectives and functional statements. However, because the objectives and functional statements are entirely qualitative, demonstrating compliance with them in isolation is not possible. Therefore, Clause 1.2.1.1.(1)(b) identifies the principle that Division B establishes the quantitative performance targets that alternative solutions must meet. In many cases, these targets are not defined very precisely by the acceptable solutions – certainly far less precisely than would be the case with a true performance code, which would have quantitative performance targets and prescribed methods of performance measurement for all aspects of building performance. Nevertheless, Clause 1.2.1.1.(1)(b) makes it clear that an effort must be made to demonstrate that an alternative solution will perform as well as a design that would satisfy the applicable acceptable solutions in Division B – not “well enough” but “as well as.”

In this sense, it is Division B that defines the boundaries between acceptable risks and the “unacceptable” risks referred to in the statements of the By-law’s objectives, i.e. the risk remaining once the applicable acceptable solutions in Division B have been implemented represents the residual level of risk deemed to be acceptable by the broad base of Canadians who have taken part in the consensus process used to develop the By-law.

## Level of Performance

Where Division B offers a choice between several possible designs, it is likely that these designs may not all provide exactly the same level of performance. Among a number of possible designs satisfying acceptable solutions in Division B, the design providing the lowest level of performance should generally be considered to establish the minimum acceptable level of performance to be used in evaluating alternative solutions for compliance with the By-law.

Sometimes a single design will be used as an alternative solution to several sets of acceptable solutions in Division B. In this case, the level of performance required of the alternative solution should be at least equivalent to the overall level of performance established by all the applicable sets of acceptable solutions taken as a whole.

Each provision in Division B has been analyzed to determine what it is intended to achieve. The resultant intent statements clarify what undesirable results each provision seeks to preclude. These statements are not a legal component of the By-law, but are advisory in nature, and can help By-law users establish performance targets for alternative solutions. They are published as part of the online By-law subscriptions and as a separate electronic document entitled “Supplement to the NBC 2015: Intent Statements,” which is available on NRC’s Web site. These intent statements should be cross referenced with the associated requirements of the Building By-law.

## Areas of Performance

A subset of the acceptable solutions in Division B may establish criteria for particular types of designs (e.g. certain types of materials, components, assemblies, or systems). Often such subsets of acceptable solutions are all attributed to the same objective: Fire Safety for example. In some cases, the designs that are normally used to satisfy this subset of acceptable solutions might also provide some benefits that could be related to some other objective: Fire Protection of the Building for example. However, if none of the applicable acceptable solutions are linked to Objective OP1, Fire Protection of the Building, it is not necessary that alternative solutions proposed to replace these acceptable solutions provide a similar benefit related to Fire Protection of the Building. In other words, the acceptable solutions in Division B establish acceptable levels of performance for compliance with the By-law only in those areas defined by the objectives and functional statements attributed to the acceptable solutions.

## Applicable Acceptable Solutions

In demonstrating that an alternative solution will perform as well as a design that would satisfy the applicable acceptable solutions in Division B, its evaluation should not be limited to comparison with the acceptable solutions to which an alternative is proposed. It is possible that acceptable solutions elsewhere in the By-law also apply. The proposed alternative solution may be shown to perform as well as the most apparent acceptable solution which it is replacing but may not perform as well as other relevant acceptable solutions. For example, an innovative sheathing material may perform adequately as sheathing in a wall system that is braced by other means but may not perform adequately as sheathing in a wall system where the sheathing must provide the structural bracing. All applicable acceptable solutions should be taken into consideration in demonstrating the compliance of an alternative solution.

**A-1.2.1.2.(1) Responsibility of Owner.** Sentence 1.1.1.1.(1) is not intended to imply that a person who becomes the owner of a building must bring the entire building into compliance with the By-law. The By-law applies only in the cases and to the extent specified by Article 1.1.1.1., and the owner of a building is therefore made responsible for ensuring the building complies with the By-law by Sentence 1.2.1.2.(1) only in the cases and to the extent specified by Article 1.1.1.1. and Part 11. If none of the provisions in Sentence 1.1.1.1.(1) and Part 11 apply to the building, the owner is not required to make any changes to the building.

**A-1.3.3.4.(1) Buildings Divided by Firewalls.** This concept relates to the provisions directly regulated by this By-law and does not apply to electrical service entrance requirements, which are regulated by other documents.

**A-1.3.3.4.(2) & (3) Buildings on Sloping Sites.** Application of the definition of grade to stepped buildings on sloping sites often results in such buildings being designated as being greater than 4 storeys in building height even though there may be only 2, 3 or 4 storeys at any one location. Figure A-1.3.3.4.(2)-A illustrates this application compared to a similar building on a flat site.

Under Sentence 1.3.3.4.(2), Building A can be considered as being 4 storeys in building height instead of 7 storeys in building height. Both Building A and B are comparable with regard to fire safety and egress.

This relaxation applies to the determination of building height only. All other requirements continue to apply as appropriate.

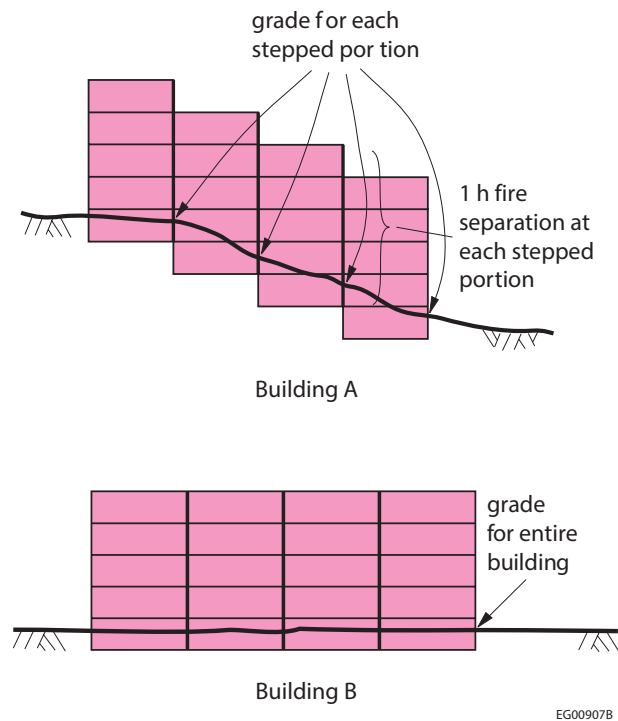
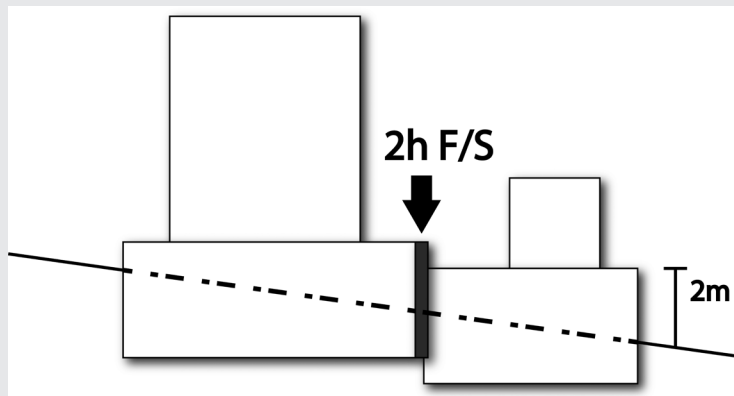

**Figure A-1.3.3.4.(2)-A**  
Application of the definition of grade

Larger buildings also have significant challenges due to sloping sites

Figure A-1.3.3.4.(2)-B illustrates this application of Sentence (3). Under Sentence 1.3.3.4.(2), Building A and B can be considered separately as these would have a level of fire safety and egress comparable with buildings constructed as separate entities.

As with the 4 storey case, this relaxation applies to the determination of building height only. All other requirements continue to apply as appropriate.



**Figure A-1.3.3.4.(2)-B**  
Application of the definition of grade for physically separate components

**A-1.3.3.6.(2)(k) Portable Classroom Exemption.** This exemption is based on the following considerations

- the building area is less than 100 m<sup>2</sup> in building area and each unit is provided with exiting directly to the exterior,
- the building is constructed with smoke detection in all major rooms and with adequate portable fire extinguishers,
- the building is properly supervised with a practised and drilled fire safety plan and with supervisory staff fully trained in securing the rapid evacuation of the facilities upon initiation of any alarm device, and
- the building, its construction type and any required fire ratings are otherwise in full conformance with the requirements of the By-law.

### A-1.4.1.2.(1) Defined Terms.

#### Access or Accessible and Persons with Disabilities

The terms “access” or “accessible” and the term “persons with disabilities” are revised in this edition of the By-law for greater alignment with the United Nations (UN) Convention on the Rights of Persons with Disabilities. This does not alter the objectives and functional statements attributed to the provisions of this By-law regarding access for persons with disabilities. The revised definitions are to provide greater clarity as to why the By-law applies requirements the way it does.

#### Ancillary Residential Unit

An ancillary residential unit is a self-contained dwelling unit that together with a larger principal dwelling unit forms a single real-estate entity. Ancillary residential units are typically created within an existing single dwelling building (house) either constructed as an addition or an alteration to an existing house or incorporated during the construction of a new house. An ancillary residential unit may have more than one storey and may be on the same level as the principal dwelling unit or be above or below it.

In a building with more than one ancillary residential unit, the principal dwelling unit along with its associated ancillary residential unit, must be either be vertically separated from all other portions of a the building that is of residential occupancy by a vertical fire separation that extends continuously through all crawlspaces, storeys and attic spaces of the vertically separate portions of a building or provided with enhanced fire protection (see Article 9.37.2.24.)

Neither the ancillary residential unit nor any other dwelling unit subordinate to a principal dwelling unit can be strata-titled or otherwise subdivided from the remainder of the principal dwelling unit under provincial legislation. This means that the principal dwelling unit and all subordinate dwelling units are registered under the same title.

#### ASTC and STC

The higher the ASTC or STC rating, the more the assembly or the system of assemblies protects occupants from noise in adjacent spaces.

These ratings, which are determined in accordance with ASTM E 413, “Classification for Rating Sound Insulation,” roughly describe the noise reduction in decibels (dB) provided by the separating floor or wall, or in the case of the ASTC rating, by the system of separating and adjoining walls and floors. For example, where an 80 dB sound on one side of a wall/floor/ceiling is reduced to 30 dB on the other side, that partition is said to have an STC of 50.

The dB scale is a logarithmic one and the human ear perceives a 10 dB reduction in sound as roughly halving the volume: for example, a 40 dB noise, subjectively, seems half as loud as a 50 dB one.

#### Care Occupancy

Support services rendered by or through care facility management refer to services provided by the organization that is responsible for the care for a period exceeding 24 consecutive hours. They do not refer to services provided by residents of dwelling units or suites, or to services arranged directly by residents of dwelling units or suites with outside agencies.

In the context of care occupancies, these services may include a daily assessment of the resident’s functioning, awareness of their whereabouts, the making of appointments for residents and reminding them of those appointments, the ability and readiness to intervene if a crisis arises for a resident, supervision in areas of nutrition or medication, and provision of transient medical services. Services may also include activities of daily living such as bathing, dressing, feeding, and assistance in the use of washroom facilities, etc. No actual treatment is provided by or through care facility management.

#### Dangerous Goods

In previous editions of the Building By-law, the terminology used to identify dangerous goods came from TC SOR/2008-34, “Transportation of Dangerous Goods Regulations (TDGR).” The TDGR apply solely to the adequate identification of hazards related to dangerous goods in the contexts of transportation and emergency response.

Dangerous goods in the workplace are identified in accordance with the “Workplace Hazardous Materials Information System (WHMIS),” established in accordance with the “*Hazardous Products Act*.” The WHMIS identification system is specifically designed with the users of the product in mind.

This edition of the Building By-law identifies dangerous goods as products regulated by the TDGR or classified under the WHMIS. In order to harmonize these two nomenclatures for dangerous goods, class descriptors were developed taking into consideration both the TDGR and WHMIS classification systems. The proposed nomenclature introduces a descriptive approach to classifying dangerous goods, which is similar to the one proposed by the Globally Harmonized System of Classification and

Rev.  
12630

Labelling of Chemicals (GHS) developed by the United Nations (UN). Canada has actively participated in the development of the GHS and has committed to its implementation through the TDGR and WHMIS regulations.

The Building By-law 2019 nomenclature takes a common sense approach that corresponds more closely to how people refer to dangerous goods on a daily basis, blending TDGR and WHMIS terminology without using nondescript numbers and letters as previously found in the Building By-law, TDGR and WHMIS.

**Table A-1.4.1.2.(1)\**  
**UN, TDGR, WHMIS and Building By-law Class Descriptors for Dangerous Goods**

UN	TDGR	WHMIS	Building By-law 2019
1	Explosives	Explosives	Explosives
2	Gases	Gases under pressure	Compressed gases
2.1	Flammable gases	Flammable gases; Flammable aerosols	Flammable gases; Flammable aerosols
2.2	Non-flammable, non-toxic gases	Gases under pressure	Non-flammable, non-toxic gases
2.2 (5.1)	–	Oxidizing gases	Oxidizing gases
2.3	Toxic gases	–	Toxic gases
3	Flammable liquids	Flammable liquids	Flammable liquids
4.1	Flammable solids	Flammable solids	Flammable solids
4.2	Substances liable to spontaneous combustion	Pyrophoric liquids; pyrophoric solids	Pyrophoric materials
4.3	Water-reactive substances	Substances and mixtures which, in contact with water, emit flammable gases	Water-reactive substances
5.1	Oxidizing substances	Oxidizing liquids; oxidizing solids	Oxidizers
5.2	Organic peroxides	Organic peroxides	Organic peroxides
6.1	Toxic substances	(1)	Toxic substances
6.2	Infectious substances	(1)	Infectious materials
7	Radioactive materials	Not covered by GHS	Radioactive materials
8	Corrosives	(2)	Corrosives
9	Miscellaneous products, substances, or organisms	(2)	Miscellaneous dangerous goods
–	–	Previously Class F	Dangerously reactive materials

**Notes to Table A-1.4.1.2.(1):**

(1) The WHMIS has various descriptors for this Class of products based on their toxicity.

(2) The WHMIS has various descriptors for this Class of products based on the nature of the danger presented by the product.

### Designated Flood Plain

The Burrard Inlet, English Bay, False Creek and Fraser River flood plains are illustrated on Diagram A1 and the wave effect zones are illustrated on Diagram A2. See Figure A-1.4.1.2.(1)-C and Figure A-1.4.1.2.(1)-D.

The Still Creek flood plain is illustrated on Figure A-1.4.1.2.(1)-E.

### Exit

Exits include doors or doorways leading directly into an exit stair or directly to the outside. In the case of an exit leading to a separate building, exits also include vestibules, walkways, bridges or balconies.

### Farm Building

Farm buildings as defined in Article 1.4.1.2. include, but are not limited to, produce storage and packing facilities, livestock and poultry housing, milking centres, manure storage facilities, grain bins, silos, feed preparation centres, farm workshops, greenhouses, farm retail centres, and horse riding, exercise and training facilities. Farm buildings may be classed as low or high human occupancy, depending on the occupant load.

Examples of farm buildings likely to be classed as low human occupancy as defined in Article 1.2.1.2. of the National Farm Building Code of Canada are livestock and poultry housing, manure and machinery storage facilities and horse exercise and training facilities where no bleachers or viewing area are provided.

Examples of farm buildings that would be classed as other than low human occupancy include farm retail centres for feeds, horticultural and livestock produce, auction barns and show areas where bleachers or other public facilities are provided. Farm work centres where the number of workers frequently exceeds the limit for low human occupancy will also be in this category.

It is possible to have areas of both high and low human occupancy in the same building provided that the structural safety and fire separation requirements for high human occupancy are met in the part thus designated.

### Fire Separation

It is generally understood that the term “fire” refers to all products of combustion, including heat and smoke. Although a fire separation is not always required to have a fire-resistance rating, it should act as a barrier to the spread of smoke and fire until some type of response is initiated. If the fire-resistance rating of a fire separation is permitted to be waived on the basis of the presence of an automatic sprinkler system, it is nonetheless the intent of the By-law that the fire separation be constructed so that it will remain in place and act as a barrier against the spread of smoke until the sprinklers have actuated.

### Flight

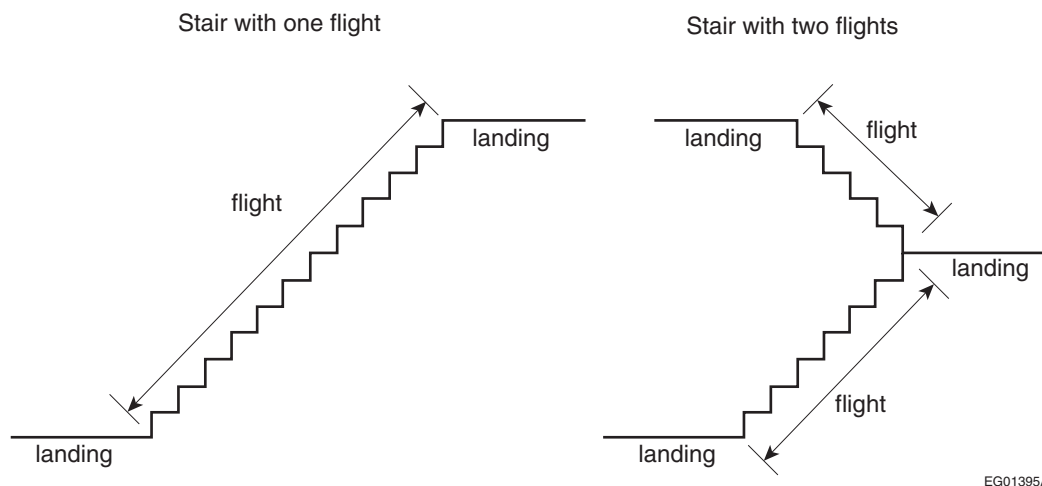

**Figure A-1.4.1.2.(1)-A**  
Flight

### Flood Construction Level Requirements

The Burrard Inlet, English Bay, False Creek and Fraser River flood plains are illustrated on Diagram A1 and the wave effect zones are illustrated on Diagram A2. See Figure A-1.4.1.2.(1)-C and Figure A-1.4.1.2.(1)-D.

The Still Creek flood construction levels are illustrated on Figure A-1.4.1.2.(1)-E.

### Grade

Localized depressions that need not be considered in the determination of the elevation of grade include such features as vehicle and pedestrian entrances and other minor depressions that do not affect accessibility for firefighting or evacuation.

### Heritage Building

Heritage buildings are buildings that are legally recognized by the Province or the City as having historic, architectural or cultural value to the community. To qualify as a heritage building under the Vancouver Building By-law, a building must be:

- protected as heritage property by the Province under the Heritage Conservation Act or the Park Act;
- subject to a heritage designation bylaw pursuant to the Municipal Act or Vancouver Charter;
- listed in the Provincial heritage register or in an inventory of heritage buildings maintained for this purpose under section 20(1)(h) of the Heritage Conservation Act.

Despite this definition of Heritage Buildings, the Chief Building Official may accept a lesser standard.

### Mechanically Vented

The definition of this term is intended to include all types of appliances and venting systems that rely entirely on fans to evacuate the products of combustion. Systems variously referred to as “forced draft,” “power vented” and “induced draft” in standards and industry terminology may be covered by this definition. The key characteristic of such systems is that they are more resistant to depressurization-induced spillage of combustion products into the building in which they are housed because the combustion venting system downstream of the fan is “sealed,” i.e. includes no draft hood or draft control device.

### Post-disaster Building

There may be circumstances where the Chief Building Official would choose to exempt certain types of buildings or parts thereof from being designated as post-disaster buildings in order to permit them to be governed by Part 9 rather than by the rest of the By-law. Such is the case in the following examples: an ambulance that is stored at a volunteer’s residence or a police station that is housed in a small shopping mall. The circumstances where such exemptions are permitted are intentionally limited by the definition of post-disaster building.

### Public Corridor

A covered mall is considered to be a public corridor and, as such, is subject to the same requirements as a public corridor.

### Rim Joist

In the field, rim joists may also be referred to as rim boards, headers or header joists.

### Service Room

Typical examples of service rooms include boiler rooms, furnace rooms, incinerator rooms, garbage handling rooms and rooms to accommodate air-conditioning or heating appliances, pumps, compressors and electrical equipment. Rooms such as elevator machine rooms and common laundry rooms are not considered to be service rooms.

### Solid Masonry Units

The net solid area of a masonry unit is calculated by determining the gross area of the bed face of the unit ( $L \times T$ ) and subtracting the cumulative areas of the hollow portions. As long as the total area of the hollow portions is 25% or less of the gross area, the unit is considered to be a solid masonry unit.

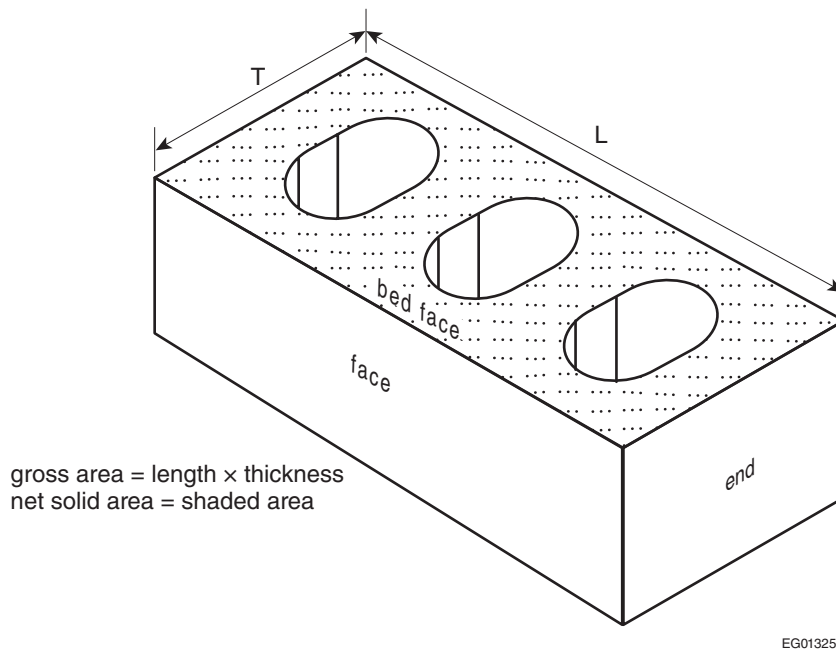

Figure A-1.4.1.2.(1)-B  
Net solid area of masonry unit



### **Storage Garage**

Entrances at which vehicles stop for a short time beneath an unenclosed canopy to pick up and drop off passengers are not considered as storage garages. As a subsidiary use, storage garages may also contain space for parking or storing other vehicles (bicycles, boat, etc.).

### **Suite**

Tenancy in the context of the term “suite” applies to both rental and ownership tenure. In a condominium arrangement, for example, dwelling units are considered separate suites even though they are individually owned. In order to be of complementary use, a series of rooms that constitute a suite must be in reasonably close proximity to each other and have access to each other either directly by means of a common doorway or indirectly by a corridor, vestibule or other similar arrangement.

The term “suite” does not apply to rooms such as service rooms, common laundry rooms and common recreational rooms that are not leased or under a separate tenure in the context of the By-law. Similarly, the term “suite” is not normally applied in the context of buildings such as schools and hospitals, since the entire building is under a single tenure. However, a room that is individually rented is considered a suite. A warehousing unit in a mini-warehouse is a suite. A rented room in a nursing home could be considered as a suite if the room was under a separate tenure. A hospital bedroom on the other hand is not considered to be under a separate tenure, since the patient has little control of that space, even though he pays the hospital a per diem rate for the privilege of using the hospital facilities, which include the sleeping areas.

For certain requirements in the By-law, the expression “room or suite” is used (e.g., travel distance). This means that the requirement applies within the rooms of suites as well as to the suite itself and to rooms that may be located outside the suite. In other places the expression “suite, and rooms not located within a suite” is used (e.g., for the installation of smoke and heat detectors). This means that the requirement applies to individual suites as defined, but not to each room within the suite. The rooms “not within a suite” would include common laundry rooms, common recreational rooms and service rooms, which are not considered as tenant-occupied space.

### **Tapered Tread**

The definition of tapered tread includes treads in curved stairs and treads in winder stairs. However, requirements for winders differ from those for other tapered treads. Requirements for tapered treads are found in Articles 3.3.1.16., 3.4.6.9., and 9.8.4.3. of Division B. Requirements for winders are found in Article 9.8.4.6. of Division B.

### **Treatment**

The ability to evacuate unassisted implies that a person is capable of recognizing and responding to an emergency given their physical, cognitive and behavioural abilities, and able to move to a safe location without the assistance of another person. For example, such persons must be able to arise and walk, or transfer from a bed or chair to a means of mobility, and leave the building or move to a safe location on their own.

### **Treatment Occupancy**

“Treatments” may include such things as surgery, intensive care, and emergency medical intervention. Treatment services differ from the services provided by care occupancies like personal care assistance or the administration of medication, and from those provided by business and personal services occupancies like dentistry or day procedures.

Illustrations for Defined Terms

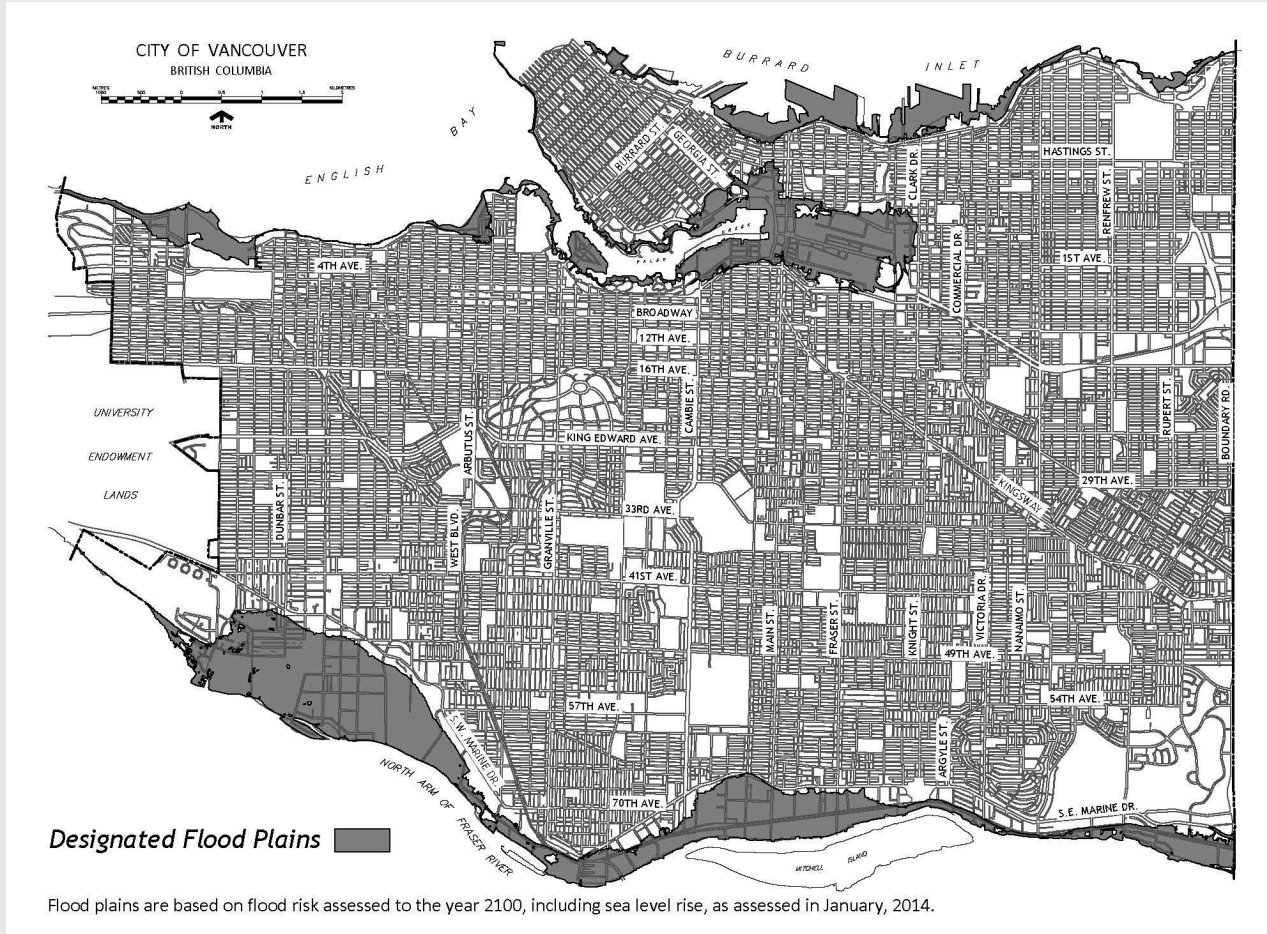

Figure A-1.4.1.2.(1)-C  
Diagram A1: Burrard Inlet, English Bay, False Creek and Fraser River Flood Plains

Diagram A2: Burrard Inlet, English Bay, False Creek and Fraser River Flood Plain Wave Effect Zone

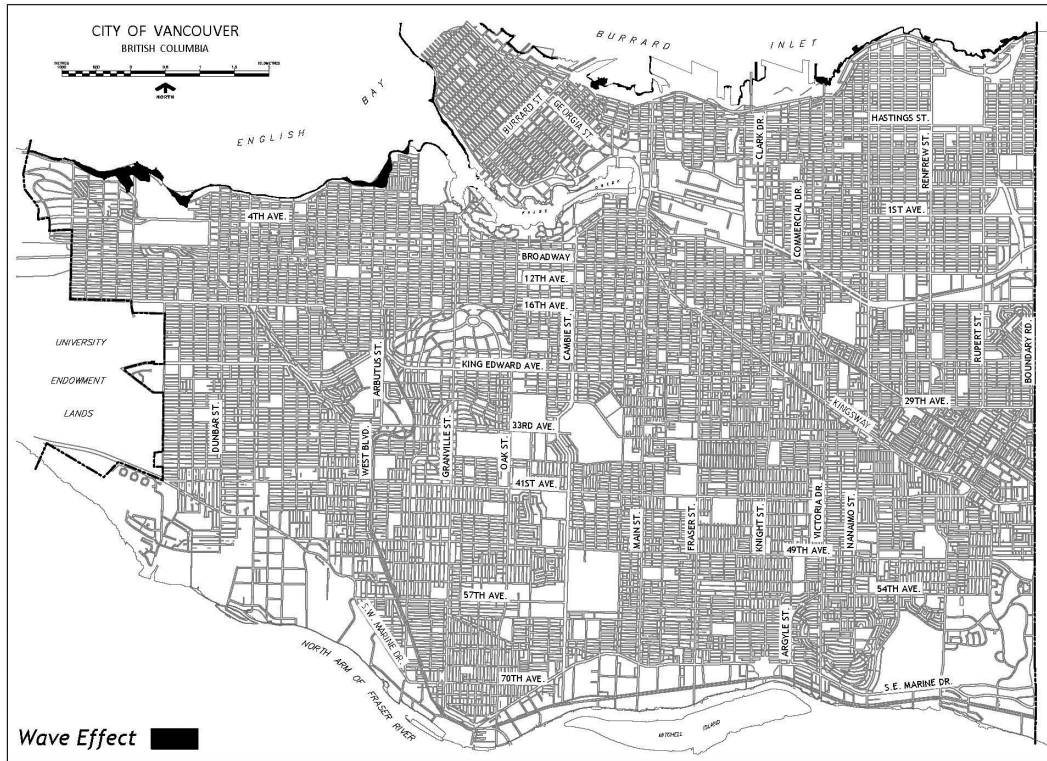
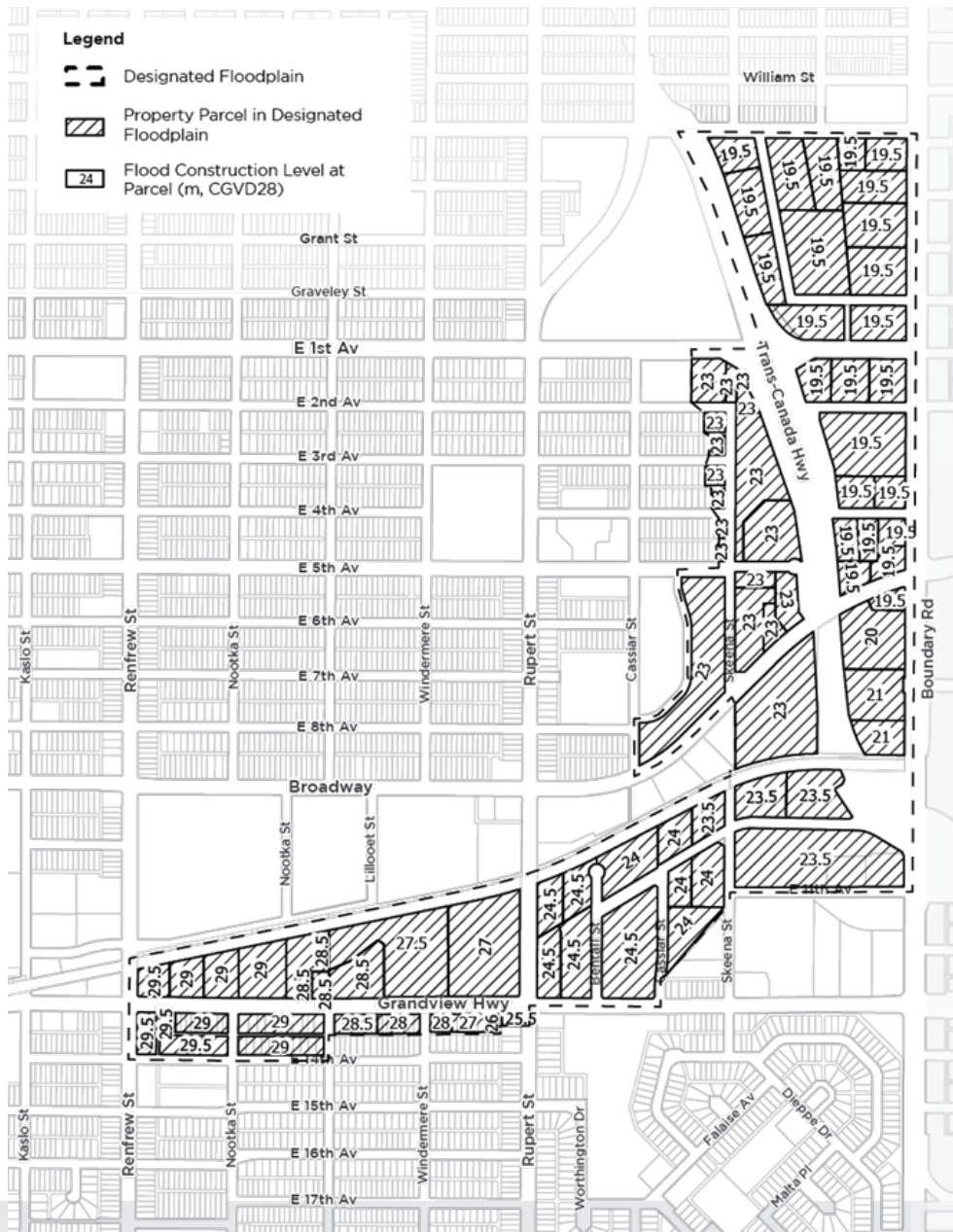

Figure A-1.4.1.2.(1)-D  
Diagram A2: Burrard Inlet, English Bay, False Creek and Fraser River Flood Plain Wave Effect Zone



**Figure A-1.4.1.2.(1)-E**  
**Diagram B: Still Creek Flood Plain and Flood Construction Levels**

Rev.  
13629

**A-1.5.1.1.(1) Application of Referenced Documents.** Documents referenced in the Building By-law may contain provisions covering a wide range of issues, including issues that are unrelated to the objectives and functional statements stated in Parts 2 and 3 of Division A respectively; e.g. aesthetic issues such as colour-fastness or uniformity. Sentence 1.5.1.1.(1) is intended to make it clear that, whereas referencing a document in the By-law generally has the effect of making the provisions of that document part of the By-law, provisions that are unrelated to buildings or to the objectives and functional statements attributed to the provisions in Division B where the document is referenced are excluded.

Furthermore, many documents referenced in the By-law contain references to other documents, which may also, in turn, refer to other documents. These secondary and tertiary referenced documents may contain provisions that are unrelated to buildings or to the objectives and functional statements of the By-law: such provisions – no matter how far down the chain of references they occur – are not included in the intent of Sentence 1.5.1.1.(1).