

Part 4

Structural Design

Section 4.1. Structural Loads and Procedures

4.1.1. General

4.1.1.1. Scope

- 1) The scope of this Part shall be as described in Subsection 1.3.3. of Division A.

4.1.1.2. Definitions

- 1) Words that appear in italics in this Part are defined in Article 1.4.1.2. of Division A.

4.1.1.3. Design Requirements

- 1) *Buildings* and their structural members and connections, including formwork and falsework, shall be designed to have sufficient structural capacity and structural integrity to safely and effectively resist all loads, effects of loads and influences that may reasonably be expected, having regard to the expected service life of *buildings*, and shall in any case satisfy the requirements of this Section. (See Note A-4.1.1.3.(1).)

- 2) *Buildings* and their structural members shall be designed for serviceability, in accordance with Articles 4.1.3.4., 4.1.3.5. and 4.1.3.6. (See Note A-4.1.1.3.(2).)

- 3) All permanent and temporary structural members, including the formwork and falsework of a *building*, shall be protected against loads exceeding the specified loads during the *construction* period except when, as verified by analysis or test, temporary overloading of a structural member would result in no impairment of that member or any other member.

- 4) Falsework, scaffolding, and formwork shall be designed in conformance with

- a) CSA S269.1, “Falsework for Construction Purposes,”
- b) CAN/CSA-S269.2-M, “Access Scaffolding for Construction Purposes,” or
- c) CAN/CSA-S269.3-M, “Concrete Formwork.”

- 5) Precautions shall be taken during all phases of *construction* to ensure that the *building* is not damaged or distorted due to loads applied during *construction*.

4.1.1.4. Structural Drawings and Related Documents

- 1) Structural drawings and related documents shall conform to the appropriate requirements of Section 2.2. of Division C. (See Subsection 2.2.4. of Division C.)

4.1.1.5. Design Basis

- 1) Except as provided in Sentence (2), *buildings* and their structural members shall be designed in conformance with the procedures and practices provided in this Part.

- 2) Provided the design is carried out by a person especially qualified in the specific methods applied and provided the design demonstrates a level of safety and performance in accordance with the requirements of Part 4, *buildings* and their structural components falling within the scope of Part 4 that are not amenable to analysis using a generally established theory may be designed by

- a) evaluation of a full-scale structure or a prototype by a loading test, or
- b) studies of model analogues.

(See Note A-4.1.1.5.(2).)

4.1.2. Specified Loads and Effects

4.1.2.1. Loads and Effects

(See Note A-4.1.2.1.)

1) Except as provided in Article 4.1.2.2., the following categories of loads, specified loads and effects shall be taken into consideration in the design of a *building* and its structural members and connections:

- D *dead load* – a permanent load due to the weight of building components, as specified in Subsection 4.1.4.,
- E earthquake load and effects – a rare load due to an earthquake, as specified in Subsection 4.1.8.,
- H a permanent load due to lateral earth pressure, including *groundwater*,
- L *live load* – a variable load due to intended use and *occupancy* (including loads due to cranes and the pressure of liquids in containers), as specified in Subsection 4.1.5.,
- L_{XC} *live load* exclusive of crane loads,
- C *live load* due to cranes including self weight,
- C_d self weight of all cranes positioned for maximum effects,
- C₇ crane bumper impact load,
- P permanent effects caused by pre-stress,
- S variable load due to snow, including ice and associated rain, as specified in Article 4.1.6.2., or due to rain, as specified in Article 4.1.6.4.,
- T effects due to contraction, expansion, or deflection caused by temperature changes, shrinkage, moisture changes, creep, ground settlement, or a combination thereof (See Note A-4.1.2.1.(1).), and
- W wind load – a variable load due to wind, as specified in Subsection 4.1.7.,

where

- a) load means the imposed deformations (i.e. deflections, displacements or motions that induce deformations and forces in the structure), forces and pressures applied to the *building* structure,
- b) permanent load is a load that changes very little once it has been applied to the structure, except during repair,
- c) variable load is a load that frequently changes in magnitude, direction or location, and
- d) rare load is a load that occurs infrequently and for a short time only.

2) Minimum specified values of the loads described in Sentence (1), as set forth in Subsections 4.1.4. to 4.1.8., shall be increased to account for dynamic effects where applicable.

3) For the purpose of determining specified loads S, W or E in Subsections 4.1.6., 4.1.7. and 4.1.8., *buildings* shall be assigned an Importance Category based on intended use and *occupancy*, in accordance with Table 4.1.2.1. (See Note A-4.1.2.1.(3).)

Table 4.1.2.1.
Importance Categories for Buildings
Forming Part of Sentence 4.1.2.1.(3)

Use and Occupancy	Importance Category
<i>Buildings</i> that represent a low direct or indirect hazard to human life in the event of failure, including: <ul style="list-style-type: none"> • low human-<i>occupancy buildings</i>, where it can be shown that collapse is not likely to cause injury or other serious consequences • minor storage <i>buildings</i> 	Low ⁽¹⁾
All <i>buildings</i> except those listed in Importance Categories Low, High and Post-disaster	Normal
<i>Buildings</i> that are likely to be used as post-disaster shelters, including <i>buildings</i> whose primary use is: <ul style="list-style-type: none"> • as an elementary, middle or secondary school • as a community centre Manufacturing and storage facilities containing toxic, explosive or other hazardous substances in sufficient quantities to be dangerous to the public if released ⁽¹⁾	High

Rev.
12630

Table 4.1.2.1. (continued)
Importance Categories for Buildings
 Forming Part of Sentence 4.1.2.1.(3)

Use and Occupancy	Importance Category
<p><i>Post-disaster buildings</i> are buildings that are essential to the provision of services in the event of a disaster, and include:</p> <ul style="list-style-type: none"> • hospitals, emergency treatment facilities and blood banks • telephone exchanges • power generating stations and electrical substations • control centres for air, land and marine transportation • public water treatment and storage facilities, and pumping stations • <i>sewage</i> treatment facilities and <i>buildings</i> having critical national defence functions • <i>buildings</i> of the following types, unless exempted from this designation by the <i>Chief Building Official</i>:(2) • emergency response facilities • fire, rescue and police stations, and housing for vehicles, aircraft or boats used for such purposes • communications facilities, including radio and television stations 	Post-disaster

Rev.
12630

Notes to Table 4.1.2.1.:

(1) See Note A-Table 4.1.2.1.

(2) See Note A-1.4.1.2.(1), Post-disaster Buildings, in Division A.

4.1.2.2. Loads Not Listed

1) Where a *building* or structural member can be expected to be subjected to loads, forces or other effects not listed in Article 4.1.2.1., such effects shall be taken into account in the design based on the most appropriate information available.

4.1.3. Limit States Design

(See Note A-4.1.3.)

4.1.3.1. Definitions

- 1) In this Subsection, the term
 - a) limit states means those conditions of a *building* structure that result in the *building* ceasing to fulfill the function for which it was designed (those limit states concerning safety are called ultimate limit states (ULS) and include exceeding the load-carrying capacity, overturning, sliding and fracture; those limit states that restrict the intended use and *occupancy* of the *building* are called serviceability limit states (SLS) and include deflection, vibration, permanent deformation and local structural damage such as cracking; and those limit states that represent failure under repeated loading are called fatigue limit states),
 - b) specified loads (C, D, E, H, L, P, S, T and W) means those loads defined in Article 4.1.2.1.,
 - c) principal load means the specified variable load or rare load that dominates in a given load combination,
 - d) companion load means a specified variable load that accompanies the principal load in a given load combination,
 - e) service load means a specified load used for the evaluation of a serviceability limit state,
 - f) principal-load factor means a factor applied to the principal load in a load combination to account for the variability of the load and load pattern and the analysis of its effects,
 - g) companion-load factor means a factor that, when applied to a companion load in the load combination, gives the probable magnitude of a companion load acting simultaneously with the factored principal load,
 - h) importance factor, I, means a factor applied in Subsections 4.1.6., 4.1.7. and 4.1.8. to obtain the specified load and take into account the consequences of failure as related to the limit state and the use and *occupancy* of the *building*,
 - i) factored load means the product of a specified load and its principal-load factor or companion-load factor,
 - j) effects refers to forces, moments, deformations or vibrations that occur in the structure,

- k) nominal resistance, R , of a member, connection or structure, is based on the geometry and on the specified properties of the structural materials,
- l) resistance factor, ϕ , means a factor applied to a specified material property or to the resistance of a member, connection or structure, and that, for the limit state under consideration, takes into account the variability of dimensions and material properties, workmanship, type of failure and uncertainty in the prediction of resistance, and
- m) factored resistance, ϕR , means the product of nominal resistance and the applicable resistance factor.

4.1.3.2. Strength and Stability

1) A *building* and its structural components shall be designed to have sufficient strength and stability so that the factored resistance, ϕR , is greater than or equal to the effect of factored loads, which shall be determined in accordance with Sentence 4.1.3.2.(2).

2) Except as provided in Sentence (3), the effect of factored loads for a *building* or structural component shall be determined in accordance with the requirements of this Article and the following load combination cases, the applicable combination being that which results in the most critical effect:

- a) for load cases without crane loads, the load combinations listed in Table 4.1.3.2.-A, and
- b) for load cases with crane loads, the load combinations listed in Table 4.1.3.2.-B.

(See Note A-4.1.3.2.(2).)

3) Other load combinations that must also be considered are the principal loads acting with the companion loads taken as zero.

4) Where the effects due to lateral earth pressure, H , restraint effects from pre-stress, P , and imposed deformation, T , affect the structural safety, they shall be taken into account in the calculations, with load factors of 1.5, 1.0 and 1.25 assigned to H , P and T respectively. (See Note A-4.1.3.2.(4).)

5) Except as provided in Sentence 4.1.8.16.(2), the counteracting factored *dead load* – 0.9D in load combination cases 2, 3 and 4 and 1.0D in load combination case 5 in Table 4.1.3.2.-A, and 0.9D in load combination cases 1 to 5 and 1.0D in load combination case 6 in Table 4.1.3.2.-B – shall be used when the *dead load* acts to resist overturning, uplift, sliding, failure due to stress reversal, and to determine anchorage requirements and the factored resistance of members. (See Note A-4.1.3.2.(5).)

6) The principal-load factor 1.5 for *live loads* L in Table 4.1.3.2.-A and L_{XC} in Table 4.1.3.2.-B may be reduced to 1.25 for liquids in tanks.

7) The companion-load factor for *live loads* L in Table 4.1.3.2.-A and L_{XC} in Table 4.1.3.2.-B shall be increased by 0.5 for storage areas, and equipment areas and *service rooms* referred to in Table 4.1.5.3.

Table 4.1.3.2.-A
Load Combinations Without Crane Loads for Ultimate Limit States
 Forming Part of Sentences 4.1.3.2.(2) and (5) to (10)

Case	Load Combination ⁽¹⁾	
	Principal Loads	Companion Loads
1	1.4D ⁽²⁾	–
2	(1.25D ⁽³⁾ or 0.9D ⁽⁴⁾) + 1.5L ⁽⁵⁾	1.0S ⁽⁶⁾ or 0.4W
3	(1.25D ⁽³⁾ or 0.9D ⁽⁴⁾) + 1.5S	1.0L ⁽⁶⁾⁽⁷⁾ or 0.4W
4	(1.25D ⁽³⁾ or 0.9D ⁽⁴⁾) + 1.4W	0.5L ⁽⁷⁾ or 0.5S
5	1.0D ⁽⁴⁾ + 1.0E ⁽⁸⁾	0.5L ⁽⁶⁾⁽⁷⁾ + 0.25S ⁽⁶⁾

Notes to Table 4.1.3.2.-A:

- (1) See Sentences 4.1.3.2.(2), (3) and (4).
- (2) See Sentence 4.1.3.2.(9).
- (3) See Sentence 4.1.3.2.(8).
- (4) See Sentence 4.1.3.2.(5).
- (5) See Sentence 4.1.3.2.(6).
- (6) See Article 4.1.5.5.
- (7) See Sentence 4.1.3.2.(7).

(8) See Sentence 4.1.3.2.(10).

Table 4.1.3.2.-B
Load Combinations With Crane Loads for Ultimate Limit States
 Forming Part of Sentences 4.1.3.2.(2), (5) to (8), and (10)

Case	Load Combination ⁽¹⁾	
	Principal Loads	Companion Loads
1	$(1.25D^{(2)} \text{ or } 0.9D^{(3)}) + (1.5C + 1.0L_{XC})$	$1.0S^{(4)} \text{ or } 0.4W$
2	$(1.25D^{(2)} \text{ or } 0.9D^{(3)}) + (1.5L_{XC}^{(5)} + 1.0C)$	$1.0S^{(4)} \text{ or } 0.4W$
3	$(1.25D^{(2)} \text{ or } 0.9D^{(3)}) + 1.5S$	$1.0C + 1.0L_{XC}^{(4)(6)}$
4	$(1.25D^{(2)} \text{ or } 0.9D^{(3)}) + 1.4W$	$(1.0C^{(7)} + 0.5L_{XC}^{(4)(6)})$
5	$(1.25D^{(2)} \text{ or } 0.9D^{(3)}) + C_7$	–
6	$1.0D^{(3)} + 1.0E^{(8)}$	$1.0C_d + 0.5L_{XC}^{(4)(6)} + 0.25S^{(4)}$

Notes to Table 4.1.3.2.-B:

- (1) See Sentences 4.1.3.2.(2), (3) and (4).
 (2) See Sentence 4.1.3.2.(8).
 (3) See Sentence 4.1.3.2.(5).
 (4) See Article 4.1.5.5.
 (5) See Sentence 4.1.3.2.(6).
 (6) See Sentence 4.1.3.2.(7).
 (7) Side thrust due to cranes need not be combined with full wind load.
 (8) See Sentence 4.1.3.2.(10).

8) Except as provided in Sentence (9), the load factor 1.25 for *dead load*, D, for *soil*, superimposed earth, plants and trees given in Tables 4.1.3.2.-A and 4.1.3.2.-B shall be increased to 1.5, except that when the *soil* depth exceeds 1.2 m, the factor may be reduced to $1 + 0.6/h_s$ but not less than 1.25, where h_s is the depth of *soil* in metres supported by the structure.

9) A principal-load factor of 1.5 shall be applied to the weight of saturated *soil* used in load combination case 1 of Table 4.1.3.2.-A.

10) Earthquake load, E, in load combination cases 5 of Table 4.1.3.2.-A and 6 of Table 4.1.3.2.-B includes horizontal earth pressure due to earthquake determined in accordance with Sentence 4.1.8.16.(7).

11) Provision shall be made to ensure adequate stability of the structure as a whole and adequate lateral, torsional and local stability of all structural parts.

12) Sway effects produced by vertical loads acting on the structure in its displaced configuration shall be taken into account in the design of *buildings* and their structural members.

4.1.3.3. Fatigue

1) A *building* and its structural components, including connections, shall be checked for fatigue failure under the effect of cyclical loads, as required in the standards listed in Section 4.3. (See Note A-4.1.3.3.(1).)

2) Where vibration effects, such as resonance and fatigue resulting from machinery and equipment, are likely to be significant, a dynamic analysis shall be carried out. (See Note A-4.1.3.3.(2).)

4.1.3.4. Serviceability

1) A *building* and its structural components shall be checked for serviceability limit states as defined in Clause 4.1.3.1.(1)(a) under the effect of service loads for serviceability criteria specified or recommended in Articles 4.1.3.5. and 4.1.3.6. and in the standards listed in Section 4.3. (See Note A-4.1.3.4.(1).)

4.1.3.5. Deflection

1) In proportioning structural members to limit serviceability problems resulting from deflections, consideration shall be given to

- a) the intended use of the *building* or member,
- b) limiting damage to non-structural members made of materials whose physical properties are known at the time of design,
- c) limiting damage to the structure itself, and
- d) creep, shrinkage, temperature changes and pre-stress.

(See Note A-4.1.3.5.(1).)

2) The lateral deflection of *buildings* due to service wind and gravity loads shall be checked to ensure that structural elements and non-structural elements whose nature is known at the time the structural design is carried out will not be damaged.

3) Except as provided in Sentence (4), the total drift per *storey* under service wind and gravity loads shall not exceed 1/500 of the *storey* height unless other drift limits are specified in the design standards referenced in Section 4.3. (See Note A-4.1.3.5.(3).)

4) The deflection limits required in Sentence (3) do not apply to industrial *buildings* or sheds if experience has proven that greater movement will have no significant adverse effects on the strength and function of the *building*.

5) The *building* structure shall be designed for lateral deflection due to E, in accordance with Article 4.1.8.13.

4.1.3.6. Vibration

1) Floor systems susceptible to vibration shall be designed so that vibrations will have no significant adverse effects on the intended *occupancy* of the *building*. (See Note A-4.1.3.6.(1).)

2) Where the fundamental vibration frequency of a structural system supporting an *assembly occupancy* used for rhythmic activities, such as dancing, concerts, jumping exercises or gymnastics, is less than 6 Hz, the effects of resonance shall be investigated by means of a dynamic analysis. (See Note A-4.1.3.6.(2).)

3) A *building* susceptible to lateral vibration under wind load shall be designed in accordance with Article 4.1.7.1. so that the vibrations will have no significant adverse effects on the intended use and *occupancy* of the *building*. (See Note A-4.1.3.6.(3).)

4.1.4. Dead Loads

4.1.4.1. Dead Loads

1) The specified *dead load* for a structural member consists of

- a) the weight of the member itself,
- b) the weight of all materials of construction incorporated into the *building* to be supported permanently by the member,
- c) the weight of *partitions*,
- d) the weight of permanent equipment, and
- e) the vertical load due to earth, plants and trees.

2) Except as provided in Sentence (5), in areas of a *building* where *partitions*, other than permanent *partitions*, are shown on the drawings, or where *partitions* might be added in the future, allowance shall be made for the weight of such *partitions*.

3) The *partition* weight allowance referred to in Sentence (2) shall be determined from the actual or anticipated weight of the *partitions* placed in any probable position, but shall be not less than 1 kPa over the area of floor being considered.

- 4) *Partition* loads used in design shall be shown on the drawings as provided in Clause 2.2.4.3.(1)(d) of Division C.
- 5) In cases where the *dead load* of the *partition* is counteractive, the load allowances referred to in Sentences (2) and (3) shall not be included in the design calculations.
- 6) Except for structures where the *dead load* of *soil* is part of the load-resisting system, where the *dead load* due to *soil*, superimposed earth, plants and trees is counteractive, it shall not be included in the design calculations. (See Note A-4.1.4.1.(6).)

4.1.5. Live Loads Due to Use and Occupancy

4.1.5.1. Loads Due to Use of Floors and Roofs

- 1) Except as provided in Sentence (2), the specified *live load* on an area of floor or roof depends on the intended use and *occupancy*, and shall not be less than either the uniformly distributed load patterns listed in Article 4.1.5.3., the loads due to the intended use and *occupancy*, or the concentrated loads listed in Article 4.1.5.9., whichever produces the most critical effect. (See Note A-4.1.5.1.(1).)
- 2) For *buildings* in the Low Importance Category as described in Table 4.1.2.1., a factor of 0.8 may be applied to the *live load*.

4.1.5.2. Uses Not Stipulated

- 1) Except as provided in Sentence (2), where the use of an area of floor or roof is not provided for in Article 4.1.5.3., the specified *live loads* due to the use and *occupancy* of the area shall be determined from an analysis of the loads resulting from the weight of
- the probable assembly of persons,
 - the probable accumulation of equipment and furnishings, and
 - the probable storage of materials.
- 2) For *buildings* in the Low Importance Category as described in Table 4.1.2.1., a factor of 0.8 may be applied to the *live load*.

4.1.5.3. Full and Partial Loading

- 1) The uniformly distributed *live load* shall be not less than the value listed in Table 4.1.5.3., which may be reduced as provided in Article 4.1.5.8., applied uniformly over the entire area or on any portions of the area, whichever produces the most critical effects in the members concerned.

Table 4.1.5.3.
Specified Uniformly Distributed Live Loads on an Area of Floor or Roof
Forming Part of Sentence 4.1.5.3.(1)

Use of Area of Floor or Roof	Minimum Specified Load, kPa
Assembly Areas	4.8
a) Except for the areas listed under b), c), d) and e), assembly areas with or without fixed seats including	
Arenas ⁽¹⁾ (areas without fixed seats that have backs)	
Auditoria	
Churches (areas without fixed seats that have backs)	
Dance floors	
Dining areas ⁽²⁾	
Foyers and entrance halls	

Table 4.1.5.3. (continued)
Specified Uniformly Distributed Live Loads on an Area of Floor or Roof
 Forming Part of Sentence 4.1.5.3.(1)

Use of Area of Floor or Roof	Minimum Specified Load, kPa
Grandstands ⁽¹⁾ (areas without fixed seats that have backs), reviewing stands and bleachers	4.8
Gymnasias	
Lecture halls ⁽¹⁾ (areas without fixed seats that have backs)	
Museums	
Promenades	
Rinks	
Stadia ⁽¹⁾ (areas without fixed seats that have backs)	
<i>Theatres</i> (areas without fixed seats that have backs)	
Other areas with similar uses	
b) Classrooms and courtrooms with or without fixed seats ⁽¹⁾	
c) Portions of assembly areas with fixed seats that have backs for the following uses:	2.9 ⁽¹⁾
Arenas	
Grandstands	
Stadia	2.4
d) Portions of assembly areas with fixed seats that have backs for the following uses:	
Churches	
Lecture halls ⁽¹⁾	2.4
<i>Theatres</i>	
e) Vomitories, <i>exits</i> , lobbies and corridors ⁽¹⁾	4.8
<i>Attics</i> ⁽¹⁾	
Accessible by a stairway in <i>residential occupancies</i> only	1.4
Having limited accessibility so that there is no storage of equipment or material	0.5
Balconies	
Exterior	4.8
Interior and <i>mezzanines</i> that could be used by an assembly of people as a viewing area ⁽¹⁾	4.8
Interior and <i>mezzanines</i> other than above	⁽³⁾
Corridors, lobbies and aisles ⁽¹⁾	
Other than those listed below	4.8
Not more than 1 200 mm in width and all upper floor corridors of residential areas only of apartments, hotels and motels (that cannot be used by an assembly of people as a viewing area) ⁽¹⁾	⁽¹⁾⁽³⁾
Equipment areas and <i>service rooms</i> including	3.6 ⁽⁴⁾
Generator rooms	
Mechanical equipment exclusive of elevators	
Machine rooms	
Pump rooms	
Transformer vaults	
Ventilating or air-conditioning equipment	
<i>Exits</i> and fire escapes	4.8
Factories	6.0 ⁽⁴⁾
Footbridges	4.8

Table 4.1.5.3. (continued)
Specified Uniformly Distributed Live Loads on an Area of Floor or Roof
 Forming Part of Sentence 4.1.5.3.(1)

Use of Area of Floor or Roof	Minimum Specified Load, kPa
Garages for	
Vehicles not exceeding 4 000 kg gross weight	2.4
Vehicles exceeding 4 000 kg but not exceeding 9 000 kg gross weight	6.0
Vehicles exceeding 9 000 kg gross weight	12.0 ⁽¹⁾
Kitchens (other than residential)	4.8
Libraries	
Stack rooms	7.2
Reading and study rooms	2.9
Office areas (not including record storage and computer rooms) located in	
<i>Basement</i> and the <i>first storey</i>	4.8
Floors above the <i>first storey</i>	2.4
Operating rooms and laboratories	3.6
Patients' bedrooms	1.9
Recreation areas that cannot be used for assembly purposes including	
Billiard rooms	3.6
Bowling alleys	
Pool rooms	
Residential areas (within the scope of Article 1.3.3.2. of Division A)	
Sleeping and living quarters in apartments, hotels, motels, boarding schools and colleges	1.9
Residential areas (within the scope of Article 1.3.3.3. of Division A)	
Bedrooms	1.9
Other areas	1.9
Stairs within <i>dwelling units</i>	1.9
Retail and wholesale areas	4.8
Roofs	1.0 ⁽¹⁾⁽⁵⁾
Sidewalks and driveways over areaways and <i>basements</i>	12.0 ⁽¹⁾⁽⁵⁾
Storage areas	4.8 ⁽⁴⁾
Toilet areas	2.4
Underground slabs with earth cover	⁽⁵⁾
Warehouses	4.8 ⁽⁴⁾

Notes to Table 4.1.5.3.:

- (1) See Note A-Table 4.1.5.3.
 (2) See Article 4.1.5.6.
 (3) See Article 4.1.5.4.
 (4) See Sentence 4.1.5.1.(1).
 (5) See Article 4.1.5.5.

4.1.5.4. Loads for Occupancy Served

- 1)** The following shall be designed to carry not less than the specified load required for the *occupancy* they serve, provided they cannot be used by an assembly of people as a viewing area:
- corridors, lobbies and aisles not more than 1 200 mm wide,
 - all corridors above the *first storey* of residential areas of apartments, hotels and motels, and
 - interior balconies and *mezzanines*.

4.1.5.5. Loads on Exterior Areas

(See Note A-4.1.5.5.)

- 1) Exterior areas accessible to vehicular traffic shall be designed for their intended use, including the weight of firefighting equipment, but not for less than the snow and rain loads prescribed in Subsection 4.1.6.
- 2) Except as provided in Sentences (3) and (4), roofs shall be designed for either the uniform *live loads* specified in Table 4.1.5.3., the concentrated *live loads* listed in Table 4.1.5.9., or the snow and rain loads prescribed in Subsection 4.1.6., whichever produces the most critical effects in the members concerned.
- 3) Exterior areas accessible to pedestrian traffic, but not vehicular traffic, shall be designed for their intended use, but not for less than the greater of
 - a) the *live load* prescribed for assembly areas in Table 4.1.5.3., or
 - b) the snow and rain loads prescribed in Subsection 4.1.6.
- 4) Roof parking decks shall be designed for either the uniformly distributed *live loads* specified in Table 4.1.5.3., the concentrated *live loads* listed in Table 4.1.5.9., or the roof snow load, whichever produces the most critical effect in the members concerned.

4.1.5.6. Loads for Dining Areas

- 1) The minimum specified *live load* listed in Table 4.1.5.3. for dining areas may be reduced to 2.4 kPa for areas in *buildings* that are being converted to dining areas, provided that the *floor area* does not exceed 100 m² and the dining area will not be used for other assembly purposes, including dancing.

4.1.5.7. More Than One Occupancy

- 1) Where an area of floor or roof is intended for 2 or more *occupancies* at different times, the value to be used from Table 4.1.5.3. shall be the greatest value for any of the *occupancies* concerned.

4.1.5.8. Variation with Tributary Area

(See Note A-4.1.5.8.)

- 1) An area used for *assembly occupancies* designed for a *live load* of less than 4.8 kPa and roofs designed for the minimum loading specified in Table 4.1.5.3. shall have no reduction for tributary area.
- 2) Where a structural member supports a tributary area of a floor or a roof, or a combination thereof, that is greater than 80 m² and either used for *assembly occupancies* designed for a *live load* of 4.8 kPa or more, or used for storage, manufacturing, retail stores, garages or as a footbridge, the specified *live load* due to use and *occupancy* is the load specified in Article 4.1.5.3. multiplied by

$$0.5 + \sqrt{20/A}$$

where A is the tributary area in square metres for this type of use and *occupancy*.

- 3) Where a structural member supports a tributary area of a floor or a roof, or a combination thereof, that is greater than 20 m² and used for any use or *occupancy* other than those indicated in Sentences (1) and (2), the specified *live load* due to use and *occupancy* is the load specified in Article 4.1.5.3. multiplied by

$$0.3 + \sqrt{9.8/B}$$

where B is the tributary area in square metres for this type of use and *occupancy*.

- 4) Where the specified *live load* for a floor is reduced in accordance with Sentence (2) or (3), the structural drawings shall indicate that a *live load* reduction factor for tributary area has been applied.

4.1.5.9. Concentrated Loads

- 1) The specified *live load* due to possible concentrations of load resulting from the use of an area of floor or roof shall not be less than that listed in Table 4.1.5.9. applied over the loaded area noted and located so as to cause maximum effects, except that for *occupancies* not listed in Table 4.1.5.9., the concentrations of load shall be determined in accordance with Article 4.1.5.2.

Table 4.1.5.9.
Specified Concentrated Live Loads on an Area of Floor or Roof
 Forming Part of Sentence 4.1.5.9.(1)

Area of Floor or Roof	Minimum Specified Concentrated Load, kN	Loaded Area, mm x mm
Roof surfaces	1.3	200 x 200
Floors of classrooms	4.5	750 x 750
Floors of offices, manufacturing <i>buildings</i> , hospital wards and <i>stages</i>	9.0	750 x 750
Floors and areas used by vehicles not exceeding 4 000 kg gross weight	18	120 x 120
Floors and areas used by vehicles exceeding 4 000 kg but not exceeding 9 000 kg gross weight	36	120 x 120
Floors and areas used by vehicles exceeding 9 000 kg gross weight	54 ⁽¹⁾	250 x 600 ⁽¹⁾
Driveways and sidewalks over areaways and <i>basements</i>	54 ⁽¹⁾	250 x 600 ⁽¹⁾

Notes to Table 4.1.5.9.:

(1) See Note A-Table 4.1.5.9.

4.1.5.10. Sway Forces in Assembly Occupancies

1) The floor assembly and other structural elements that support fixed seats in any *building* used for *assembly occupancies* accommodating large numbers of people at one time, such as grandstands, stadia and *theatre* balconies, shall be designed to resist a horizontal force equal to not less than 0.3 kN for each metre length of seats acting parallel to each row of seats, and not less than 0.15 kN for each metre length of seats acting at right angles to each row of seats, based on the assumption that these forces are acting independently of each other.

4.1.5.11. Crane-Supporting Structures and Impact of Machinery and Equipment

(See Note A-4.1.5.11.)

- 1) The minimum specified load due to equipment, machinery or other objects that may produce impact shall be the sum of the weight of the equipment or machinery and its maximum lifting capacity, multiplied by an appropriate factor listed in Table 4.1.5.11.
- 2) Crane-supporting structures shall be designed for the appropriate load combinations listed in Article 4.1.3.2.
- 3) Crane runway structures shall be designed to resist a horizontal force applied normal to the top of the rails equal to not less than 20% of the sum of the weights of the lifted load and the crane trolley (excluding other parts of the crane).
- 4) The force described in Sentence (3) shall be equally distributed on each side of the runway and shall be assumed to act in either direction.
- 5) Crane runway structures shall be designed to resist a horizontal force applied parallel to the top of the rails equal to not less than 10% of the maximum wheel loads of the crane.

Table 4.1.5.11.
Factors for the Calculation of Impact Loads
 Forming Part of Sentence 4.1.5.11.(1)

Cause of Impact	Factor
Operation of cab or radio-operated cranes	1.25
Operation of pendant or hand-operated cranes	1.10
Operation of elevators	⁽¹⁾
Supports for light machinery, shaft or motor-driven	1.20
Supports for reciprocating machinery (e.g. compressors)	1.50
Supports for power-driven units (e.g. piston engines)	1.50

Notes to Table 4.1.5.11.:

(1) See the Elevating Devices Safety Regulation

4.1.5.12. Bleachers

- 1) Bleacher seats shall be designed for a uniformly distributed *live load* of 1.75 kN for each linear metre or for a concentrated load of 2.2 kN distributed over a length of 0.75 m, whichever produces the most critical effect on the supporting members.
- 2) Bleachers shall be checked by the erector after erection to ensure that all structural members, including bracing specified in the design, have been installed.
- 3) Telescopic bleachers shall be provided with locking devices to ensure stability while in use.

4.1.5.13. Helicopter Landing Areas

- 1) Helicopter landing areas on roofs shall be constructed in conformance with the requirements for heliports contained in TC SOR/96-433, “Canadian Aviation Regulations – Part III.”

4.1.5.14. Loads on Guards and Handrails

(See Note A-4.1.5.14. and 4.1.5.15.(1).)

- 1) The minimum specified horizontal load applied outward at the minimum required height of every required *guard* shall be
 - a) 3.0 kN/m for open viewing stands without fixed seats and for *means of egress* in grandstands, stadia, bleachers and arenas,
 - b) a concentrated load of 1.0 kN applied at any point, so as to produce the most critical effect, for access ways to equipment platforms, contiguous stairs and similar areas where the gathering of many people is improbable, and
 - c) 0.75 kN/m or a concentrated load of 1.0 kN applied at any point so as to produce the most critical effect, whichever governs for locations other than those described in Clauses (a) and (b).
- 2) The minimum specified horizontal load applied inward at the minimum required height of every required *guard* shall be half that specified in Sentence (1).
- 3) Individual elements within the *guard*, including solid panels and pickets, shall be designed for a load of 0.5 kN applied outward over an area of 100 mm by 100 mm located at any point in the element or elements so as to produce the most critical effect.
- 4) The size of the opening between any two adjacent vertical elements within a *guard* shall not exceed the limits required by Part 3 when each of these elements is subjected to a specified *live load* of 0.1 kN applied in opposite directions in the in-plane direction of the *guard* so as to produce the most critical effect.
- 5) The loads required in Sentence (3) need not be considered to act simultaneously with the loads provided for in Sentences (1), (2) and (6).
- 6) The minimum specified load applied vertically at the top of every required *guard* shall be 1.5 kN/m and need not be considered to act simultaneously with the horizontal load provided for in Sentence (1).
- 7) Handrails and their supports shall be designed and constructed to withstand the following loads, which need not be considered to act simultaneously:
 - a) a concentrated load not less than 0.9 kN applied at any point and in any direction for all handrails, and
 - b) a uniform load not less than 0.7 kN/m applied in any direction to handrails not located within *dwelling units*.

4.1.5.15. Loads on Vehicle Guardrails

- 1) Vehicle guardrails shall be designed for a concentrated load of 22 kN applied horizontally outward at any point 500 mm above the floor surface so as to produce the most critical effect. (See Note A-4.1.5.14. and 4.1.5.15.(1).)
- 2) The loads required in Sentence (1) need not be considered to act simultaneously with the loads provided for in Article 4.1.5.14.

4.1.5.16. Loads on Walls Acting As Guards

1) Where the floor elevation on one side of a wall, including a wall around a shaft, is more than 600 mm higher than the elevation of the floor or ground on the other side, the wall shall be designed to resist the appropriate outward lateral design loads prescribed elsewhere in Subsection 4.1.5. or 0.5 kPa acting outward, whichever produces the more critical effect.

4.1.5.17. Firewalls

(See Note A-4.1.5.17.)

- 1) *Firewalls* shall be designed to resist the maximum effect due to
 - a) the appropriate lateral design loads prescribed elsewhere in this Section, or
 - b) a factored lateral load of 0.5 kPa under fire conditions, as described in Sentence (2).
- 2) Under fire conditions, where the *fire-resistance rating* of the structure is less than that of the *firewall*,
 - a) lateral support shall be assumed to be provided by the structure on one side only, or
 - b) another structural support system capable of resisting the loads imposed by a fire on either side of the *firewall* shall be provided.

4.1.5.18. Loads for Building Maintenance

1) *Buildings* shall be designed to support the loads and forces required to support *building* maintenance equipment.

4.1.6. Loads Due to Snow and Rain**4.1.6.1. Specified Load Due to Rain or to Snow and Associated Rain**

1) The specified load on a roof or any other *building* surface subject to snow and associated rain shall be the snow load specified in Article 4.1.6.2., or the rain load specified in Article 4.1.6.4., whichever produces the more critical effect.

4.1.6.2. Specified Snow Load

(See Note A-4.1.6.2.)

1) The specified load, S , due to snow and associated rain accumulation on a roof or any other *building* surface subject to snow accumulation shall be calculated using the formula

$$S = I_s [S_s (C_b C_w C_s C_a) + S_r]$$

where

- I_s = importance factor for snow load as provided in Table 4.1.6.2.-A,
- S_s = 1-in-50-year ground snow load, in kPa, determined in accordance with Subsection 1.1.3.,
- C_b = basic roof snow load factor in Sentence (2),
- C_w = wind exposure factor in Sentences (3) and (4),
- C_s = slope factor in Sentences (5), (6) and (7),
- C_a = accumulation factor in Sentence (8), and
- S_r = 1-in-50-year associated rain load, in kPa, determined in accordance with Subsection 1.1.3., but not greater than $S_s(C_b C_w C_s C_a)$.

Table 4.1.6.2.-A
Importance Factor for Snow Load, I_s
 Forming Part of Sentence 4.1.6.2.(1)

Importance Category	Importance Factor, I_s	
	ULS	SLS
Low	0.8	0.9
Normal	1	0.9
High	1.15	0.9
Post-disaster	1.25	0.9

2) The basic roof snow load factor, C_b , shall

a) be determined as follows:

i) $C_b = 0.8$ for $l_c \leq \left(\frac{70}{C_w^2}\right)$, and

ii) $C_b = \frac{1}{C_w} \left[1 - (1 - 0.8C_w) \exp\left(-\frac{l_c C_w^2 - 70}{100}\right) \right]$ for $l_c > \left(\frac{70}{C_w^2}\right)$

where

l_c = characteristic length of the upper or lower roof, defined as $2w-w^2/l$, in m,

w = smaller plan dimension of the roof, in m, and

l = larger plan dimension of the roof, in m, or

b) conform to Table 4.1.6.2.-B, using linear interpolation for intermediate values of $l_c C_w^2$.

(See Note A-4.1.6.2.(2).)

3) Except as provided for in Sentence (4), the wind exposure factor, C_w , shall be 1.0.

4) For *buildings* in the Low and Normal Importance Categories as set out in Table 4.1.2.1., the wind exposure factor, C_w , given in Sentence (3) may be reduced to 0.75 for rural areas only, or to 0.5 for exposed areas north of the treeline, where

- the *building* is exposed on all sides to wind over open terrain as defined in Clause 4.1.7.3.(5)(a), and is expected to remain so during its life,
- the area of roof under consideration is exposed to the wind on all sides with no significant obstructions on the roof, such as parapet walls, within a distance of at least 10 times the difference between the height of the obstruction and $C_b C_w S_s / \gamma$ metres, where γ is the specific weight of snow on roofs as specified in Article 4.1.6.13., and
- the loading does not involve the accumulation of snow due to drifting from adjacent surfaces.

5) Except as provided for in Sentences (6) and (7), the slope factor, C_s , shall be

- 1.0 where the roof slope, α , is equal to or less than 30° ,
- $(70^\circ - \alpha)/40^\circ$ where α is greater than 30° but not greater than 70° , and
- 0 where α exceeds 70° .

Table 4.1.6.2.-B
Basic Roof Snow Load Factor for $I_C > (70/C_w^2)$
 Forming Part of Sentence 4.1.6.2.(2)

Value of $I_C C_w^2$	Value of C_w		
	1.0	0.75	0.5
	Value of C_b		
70	0.80	0.80	0.80
80	0.82	0.85	0.91
100	0.85	0.94	1.11
120	0.88	1.01	1.27
140	0.90	1.07	1.40
160	0.92	1.12	1.51
180	0.93	1.16	1.60
200	0.95	1.19	1.67
220	0.96	1.21	1.73
240	0.96	1.24	1.78
260	0.97	1.25	1.82
280	0.98	1.27	1.85
300	0.98	1.28	1.88
320	0.98	1.29	1.90
340	0.99	1.30	1.92
360	0.99	1.30	1.93
380	0.99	1.31	1.95
400	0.99	1.31	1.96
420	0.99	1.32	1.96
440	1.00	1.32	1.97
460	1.00	1.32	1.98
480	1.00	1.32	1.98
500	1.00	1.33	1.98
520	1.00	1.33	1.99
540	1.00	1.33	1.99
560	1.00	1.33	1.99
580	1.00	1.33	1.99
600	1.00	1.33	1.99
620	1.00	1.33	2.00

6) The slope factor, C_s , for unobstructed slippery roofs where snow and ice can slide completely off the roof shall be

- a) 1.0 where the roof slope, α , is equal to or less than 15° ,
- b) $(60^\circ - \alpha)/45^\circ$ where α is greater than 15° but not greater than 60° , and
- c) 0 where α exceeds 60° .

7) Unless otherwise stated in this Subsection, the slope factor, C_s , shall be 1.0 when used in conjunction with accumulation factors for increased snow loads.

8) The accumulation factor, C_a , shall be 1.0, which corresponds to the uniform snow load case, except that where appropriate for the shape of the roof, it shall be assigned other values that account for

- a) increased non-uniform snow loads due to snow drifting onto a roof that is at a level lower than other parts of the same *building* or at a level lower than another *building* within 5 m of it horizontally, as prescribed in Articles 4.1.6.5., 4.1.6.6. and 4.1.6.8.,

- b) increased non-uniform snow loads on areas adjacent to roof projections, such as penthouses, large *chimneys* and equipment, as prescribed in Articles 4.1.6.7. and 4.1.6.8.,
- c) non-uniform snow loads on gable, arch or curved roofs and domes, as prescribed in Articles 4.1.6.9. and 4.1.6.10.,
- d) increased snow or ice loads due to snow sliding as prescribed in Article 4.1.6.11.,
- e) increased snow loads in roof valleys, as prescribed in Article 4.1.6.12., and
- f) increased snow or ice loads due to meltwater draining from adjacent *building* elements and roof projections.

9) For shapes not addressed in Sentence (8), C_a corresponding to the non-uniform snow load case shall be established based on applicable field observations, special analyses including local climatic effects, appropriate model tests, or a combination of these methods.

4.1.6.3. Full and Partial Loading

1) A roof or other *building* surface and its structural members subject to loads due to snow accumulation shall be designed for the specified load given in Sentence 4.1.6.2.(1), distributed over the entire loaded area.

2) In addition to the distribution mentioned in Sentence (1), flat roofs and shed roofs, gable roofs of 15° slope or less, and arch or curved roofs shall be designed for the specified uniform snow load indicated in Sentence 4.1.6.2.(1), which shall be calculated using the accumulation factor $C_a = 1.0$, distributed on any one portion of the loaded area and half of this load on the remainder of the loaded area, in such a way as to produce the most critical effects on the member concerned. (See Note A-4.1.6.3.(2).)

4.1.6.4. Specified Rain Load

1) Except as provided in Sentence (4), the specified load, S , due to the accumulation of rainwater on a surface whose position, shape and deflection under load make such an accumulation possible, is that resulting from the one-day rainfall determined in conformance with Subsection 1.1.3. and applied over the horizontal projection of the surface and all tributary surfaces. (See Note A-4.1.6.4.(1).)

2) The provisions of Sentence (1) apply whether or not the surface is provided with a means of drainage, such as rainwater leaders.

3) Except as provided in Sentence 4.1.6.2.(1), loads due to rain need not be considered to act simultaneously with loads due to snow. (See Note A-4.1.6.4.(3).)

4) Where scuppers are provided and where the position, shape and deflection of the loaded surface make an accumulation of rainwater possible, the loads due to rain shall be the lesser of either the one-day rainfall determined in conformance with Subsection 1.1.3. or a depth of rainwater equal to 30 mm above the level of the scuppers, applied over the horizontal projection of the surface and tributary areas.

4.1.6.5. Multi-level Roofs

1) The drifting load of snow on a roof adjacent to a higher roof shall be taken as trapezoidal, as shown in Figure 4.1.6.5.-A, and the accumulation factor, C_a , shall be determined as follows:

$$C_a = C_{a0} - (C_{a0} - 1)(x/x_d) \text{ for } 0 \leq x \leq x_d,$$

or

$$C_a = 1.0 \text{ for } x > x_d$$

where

C_{a0} = peak value of C_a at $x = 0$ determined in accordance with Sentences (3) and (4) and as shown in Figure 4.1.6.5.-B,

x = distance from roof step as shown in Figure 4.1.6.5.-A, and

x_d = length of drift determined in accordance with Sentence (2) and as shown in Figure 4.1.6.5.-A.

2) The length of the drift, x_d , shall be calculated as follows:

$$x_d = 5 \frac{C_b S_s}{\gamma} (C_{a0} - 1)$$

where

γ = specific weight of snow as specified in Article 4.1.6.13.

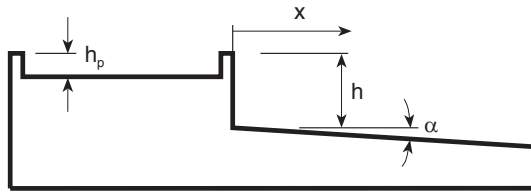

$$x_d = 5 \frac{C_b S_s}{\gamma} (C_{a0} - 1)$$

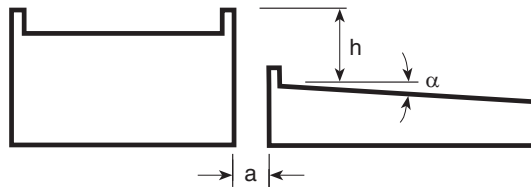

C_{a0} = the lesser of

$$\beta_1 \frac{\gamma h}{C_b S_s}$$

and

$$\frac{F}{C_b}$$

Distribution of snow load, S

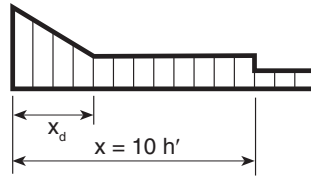

$$h' = h - \frac{C_b C_w S_s}{\gamma}$$

x	Factors ⁽¹⁾		
	C_w	$C_s^{(2)}$	C_a
0	1.0	$f(\alpha)$	C_{a0}
$0 < x \leq x_d$	1.0	$f(\alpha)$	$C_{a0} - (C_{a0} - 1) \frac{x}{x_d}$
$x_d < x \leq 10 h'$	1.0	$f(\alpha)$	1.0
$x > 10 h'$	1.0 for non-exposed roof areas 0.75 for exposed roof areas 0.5 for exposed roof areas north of tree line	$f(\alpha)$	1.0

EG01301B

Figure 4.1.6.5.-A
Snow load factors for lower level roofs

Forming Part of Sentences 4.1.6.5.(1) and (3) and 4.1.6.6.(1)

Notes to Figure 4.1.6.5.-A:

- (1) If $a > 5$ m or $h \leq 0.8 S_s / \gamma$, drifting from the higher roof need not be considered.
- (2) For lower roofs with parapets, $C_s = 1.0$, otherwise it varies as a function of slope α as defined in Sentences 4.1.6.2.(5) and (6).

- 3) The value of C_{a0} for each of Cases I, II, and III shall be the lesser of

$$C_{a0} = \beta \frac{\gamma h}{C_b S_s}$$

and

$$C_{a0} = \frac{F}{C_b}$$

where

β = 1.0 for Case I, and 0.67 for Cases II and III,

h = difference in elevation between the lower roof surface and the top of the parapet on the upper roof as shown in Figure 4.1.6.5.-A, and

$$F = 0.35\beta \sqrt{\frac{\gamma(l_{cs} - 5h'_p)}{S_s}} + C_b, \text{ but } F \leq 5 \text{ for } C_{ws} = 1.0$$

where

C_{ws} = value of C_w applicable to the source of drifting,

l_{cs} = characteristic length of the source area for drifting, defined as $l_{cs} = 2w_s - \frac{w_s^2}{l_s}$, where w_s and l_s are respectively the shorter and longer dimensions of the relevant source areas for snow drifting shown in Figure 4.1.6.5.-B for Cases I, II and III, and

$$h'_p = h_p - \left(\frac{0.8S}{\gamma} \right), \text{ but } 0 \leq h'_p \leq \left(\frac{l_{cs}}{5} \right)$$

where

h_p = height of the roof perimeter parapet of the source area, to be taken as zero unless all the roof edges of the source area have parapets.

- 4) The value of C_{a0} shall be the highest of Cases I, II and III, considering the different roof source areas for drifting snow, as specified in Sentence (3) and Figure 4.1.6.5.-B.

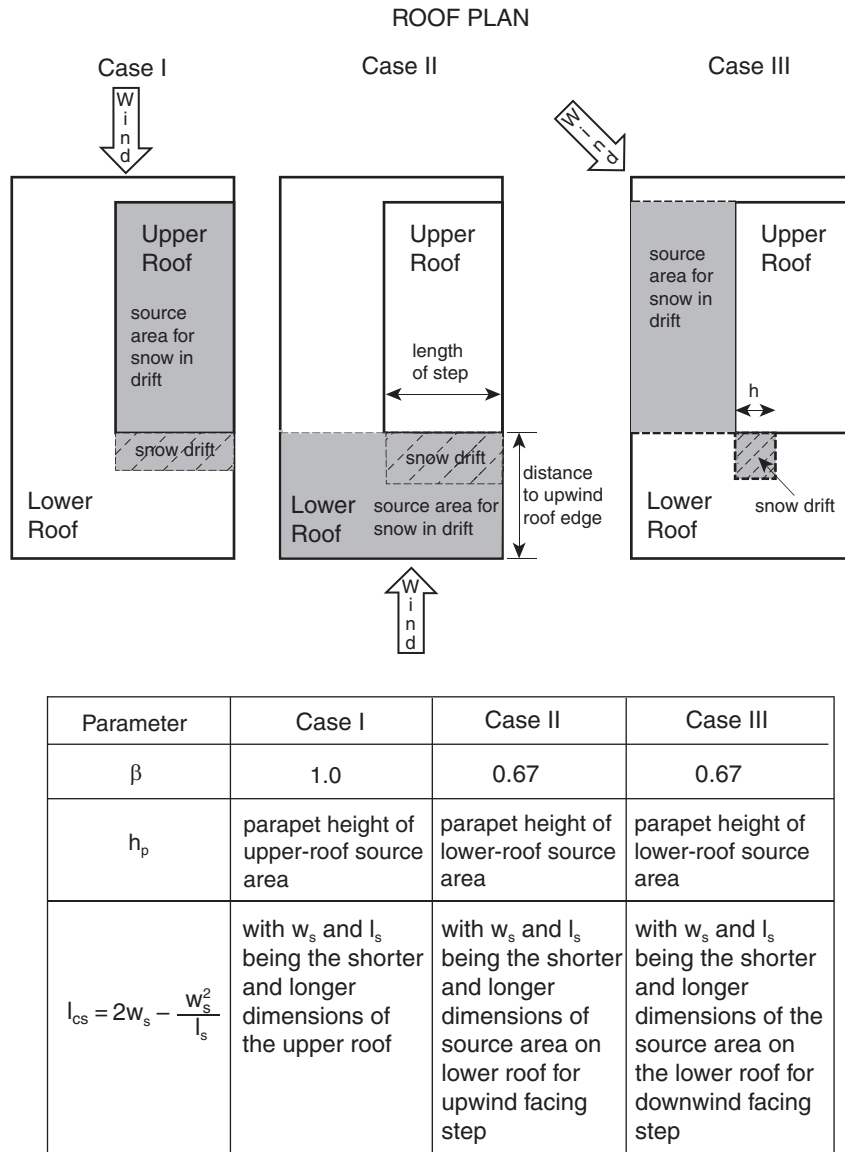

EG01302B

Figure 4.1.6.5.-B
Snow load cases I, II and III for lower level roofs
 Forming Part of Sentences 4.1.6.5.(1), (3) and (4)

4.1.6.6. Horizontal Gap between a Roof and a Higher Roof

1) Where the roof of one *building* is separated by a distance, a , from an adjacent *building* with a higher roof as shown in Figure 4.1.6.5.-A, the influence of the adjacent *building* on the value of the accumulation factor, C_a , for the lower roof shall be determined as follows:

- a) if $a > 5$ m, the influence of the adjacent *building* on C_a for the lower roof can be ignored, and
- b) if $a \leq 5$ m, C_a for the lower roof shall be calculated in accordance with Article 4.1.6.5. for values of $x \geq a$.

4.1.6.7. Areas Adjacent to Roof Projections

1) Except as provided in Sentences (2) and (3), the accumulation factor, C_a , for areas adjacent to roof-mounted vertical projections shall be calculated in accordance with Sentence 4.1.6.5.(1) using the following values for the peak accumulation factor, C_{a0} , and the drift length, x_d :

a) C_{a0} shall be taken as the lesser of

$$0.67 \frac{\gamma h}{C_b S_s} \quad \text{and} \quad \frac{\gamma l_0}{7.5 C_b S_s} + 1, \text{ and}$$

b) x_d shall be taken as the lesser of $3.35h$ and $(2/3)l_0$, where

h = height of the projection, and

l_0 = longest horizontal dimension of the projection.

(See Note A-4.1.6.7.(1).)

2) C_a is permitted to be calculated in accordance with Article 4.1.6.5. for larger projections.

(See Note A-4.1.6.7.(2).)

3) Where the longest horizontal dimension of the roof projection, l_0 , is less than 3 m, the drift surcharge adjacent to the projection need not be considered.

4.1.6.8. Snow Drift at Corners

1) The drift loads on the lower level roof against the two faces of an outside corner of an upper level roof or roof obstruction shall be extended radially around the corner as shown in Figure 4.1.6.8.-A and may be taken as the least severe of the drift loads lying against the two faces of the corner.

2) The drift loads on the lower level roof against the two faces of an inside corner of an upper level roof or a parapet shall be calculated for each face and applied as far as the bisector of the corner angle as shown in Figure 4.1.6.8.-B.

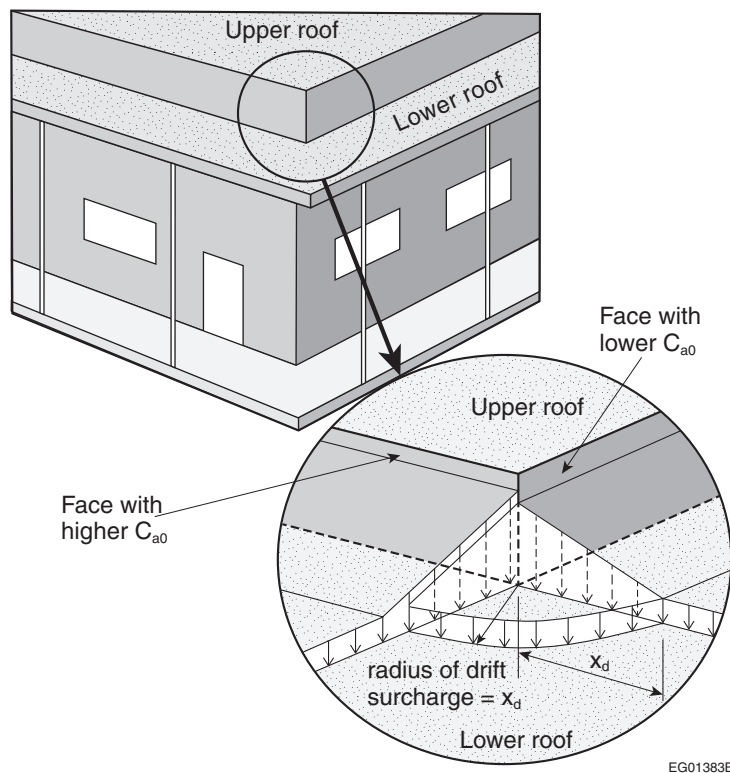

Figure 4.1.6.8.-A
Snow load at outside corner
Forming Part of Sentence 4.1.6.8.(1)

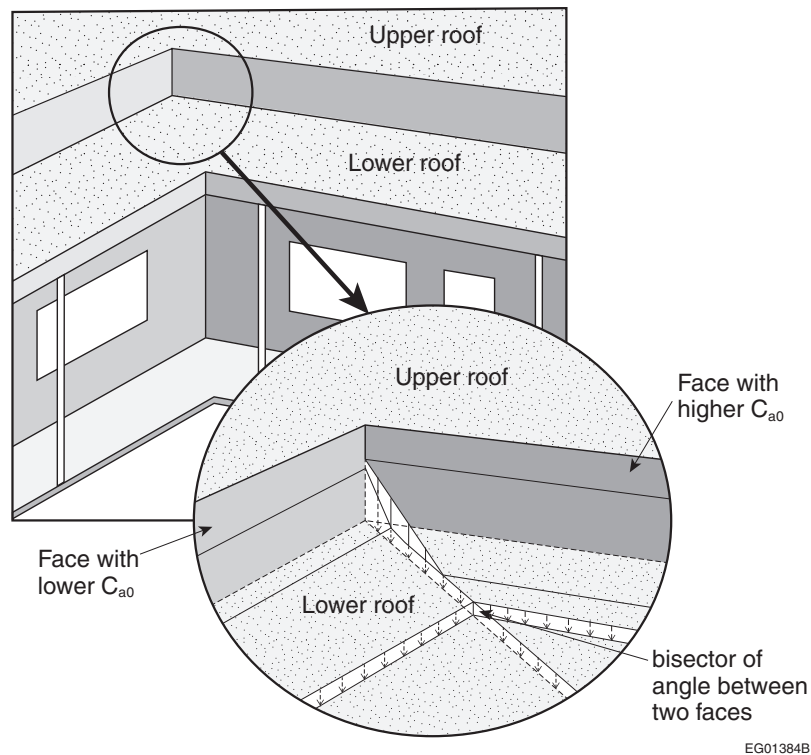

Figure 4.1.6.8.-B
Snow load at inside corner
 Forming Part of Sentence 4.1.6.8.(2)

4.1.6.9. Gable Roofs

(See Note A-4.1.6.9.)

- 1) For all gable roofs, the full and partial load cases defined in Article 4.1.6.3. shall be considered.
- 2) For gable roofs with a slope $\alpha > 15^\circ$, the unbalanced load case shall also be considered by setting the values of the accumulation factor, C_a , as follows:
 - a) on the upwind side of the roof peak, C_a shall be taken as 0, and
 - b) on the downwind side of the roof peak, C_a shall be taken as
 - i) $0.25 + \alpha/20$, where $15^\circ \leq \alpha \leq 20^\circ$, and
 - ii) 1.25, where $20^\circ < \alpha \leq 90^\circ$.
- 3) For all gable roofs, the slope factor, C_s , shall be as prescribed in Sentences 4.1.6.2.(5) and (6).
- 4) For all gable roofs, the wind exposure factor, C_w , shall be
 - a) as prescribed in Sentences 4.1.6.2.(3) and (4) for the full and partial load cases, and
 - b) 1.0 for the unbalanced load case referred to in Sentence (2).

4.1.6.10. Arch Roofs, Curved Roofs and Domes

- 1) For all arch roofs, curved roofs and domes, the full and partial load cases defined in Article 4.1.6.3. shall be considered.
- 2) For arch roofs, curved roofs and domes with a rise-to-span ratio $h/b > 0.05$ (See Figure 4.1.6.10.-A), the load cases provided in Sentences (3) to (7) shall also be considered.

- 3) For arch roofs with a slope at the edge $\alpha_e \leq 30^\circ$ (See Figure 4.1.6.10.-A and Table 4.1.6.10.), C_a shall be
- taken as 0 on the upwind side of the peak, and
 - on the downwind side of the peak, taken as

$$C_a = \frac{xh}{0.03C_b b^2} \text{ for } 0.05 < \frac{h}{b} \leq 0.12 \text{ and}$$

$$C_a = \frac{4x}{C_b b} \text{ for } \frac{h}{b} > 0.12$$

where

- x = horizontal distance from the roof peak,
- h = height of arch, and
- b = width of arch.

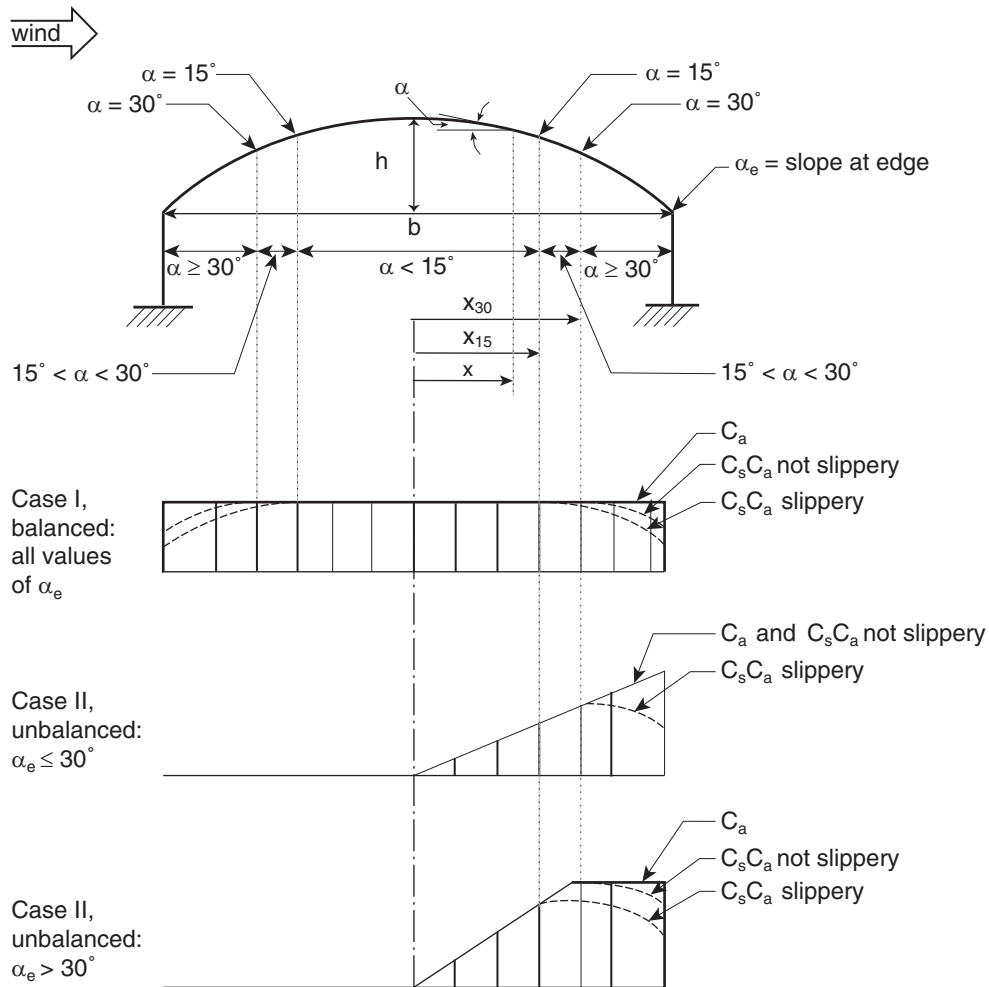

EG01307B

Figure 4.1.6.10.-A
Accumulation factors for arch roofs and curved roofs
 Forming Part of Sentences 4.1.6.10.(2) to (4)

Note to Figure 4.1.6.10.-A:

- (1) Refer to Table 4.1.6.10. for applicable values of C_w and Sentences 4.1.6.2.(5) and (6) for applicable values of C_s .

- 4) For arch roofs with a slope at the edge $\alpha_e > 30^\circ$ (See Figure 4.1.6.10.-A and Table 4.1.6.10.), C_a shall be
- taken as 0 on the upwind side of the peak, and
 - on the downwind side of the peak,
 - for the part of the roof between the peak and point where the slope $\alpha = 30^\circ$, taken as

$$C_a = \frac{xh}{0.06C_b x_{30} b} \text{ for } 0.05 < \frac{h}{b} \leq 0.12, \text{ and}$$

$$C_a = \frac{2x}{C_b x_{30}} \text{ for } \frac{h}{b} > 0.12$$

where

x, h, b = as specified in Sentence (2), and

x_{30} = value of x where the slope $\alpha = 30^\circ$, and

- for the part of the roof where the slope $\alpha > 30^\circ$, taken as

$$C_a = \frac{h}{0.06C_b b} \text{ for } 0.05 < \frac{h}{b} \leq 0.12, \text{ and}$$

$$C_a = \frac{2}{C_b} \text{ for } \frac{h}{b} > 0.12$$

- 5) Except as provided in Sentence (6), C_a for curved roofs shall be determined in accordance with the requirements for arch roofs stated in Sentences (3) and (4).

Table 4.1.6.10.
Load Cases for Arch Roofs, Curved Roofs and Domes
 Forming Part of Sentences 4.1.6.10.(3), (4) and (9)

Load Case	Range of Application	Factors			
		All Arch or Curved Roofs and Domes	Arch and Curved Roofs		Domes
		C_w	C_a Upwind Side	C_a Downwind Side	C_a Downwind Side
Case I	All values of h/b	As stated in 4.1.6.2.(3) and (4)	1.0	1.0	1.0
Case II	Slope at edge $\leq 30^\circ$ $h/b > 0.05$ all values of x	1.0	0.0	$C_a = \frac{xh}{0.03C_b b^2}$ for $\frac{h}{b} \leq 0.12$ $C_a = \frac{4x}{C_b b}$ for $\frac{h}{b} > 0.12$	$C_a(x, y) = C_a(x, 0) \left(1 - \frac{y}{r}\right)$
	Slope at edge $> 30^\circ$ $h/b > 0.05$ $0 < x < x_{30}$	1.0	0.0	$C_a = \frac{xh}{0.06C_b x_{30} b}$ for $\frac{h}{b} \leq 0.12$ $C_a = \frac{2x}{C_b x_{30}}$ for $\frac{h}{b} > 0.12$	
	Slope at edge $> 30^\circ$ $h/b > 0.05$ $x \geq x_{30}$	1.0	0.0	$C_a = \frac{xh}{0.06C_b b}$ for $\frac{h}{b} \leq 0.12$ $C_a = \frac{2}{C_b}$ for $\frac{h}{b} > 0.12$	

- 6) Where the slope, α , of a curved roof at its peak is greater than 10° , C_a shall be determined in accordance with the requirements for gable roofs stated in Article 4.1.6.9. using a slope equal to the mean slope of the curved roof.

- 7) For domes of circular plan form (See Figure 4.1.6.10.-B), C_a shall
- along the central axis parallel to the wind, vary in the same way as for an arch roof with the same rise-to-span ratio, h/b , and
 - off this axis, vary according to

$$C_a(x, y) = C_a(x, 0) \left(1 - \frac{y}{r}\right)$$

where

$C_a(x, y)$ = value of C_a at location (x, y) ,

$C_a(x, 0)$ = value of C_a on the central axis parallel to the wind,

x = distance along the central axis parallel to the wind,

y = horizontal coordinate normal to the x direction, and

r = radius of dome.

- 8) For all arch roofs, curved roofs and domes, the slope factor, C_s , shall be as prescribed in Sentences 4.1.6.2.(5) and (6).

- 9) For all arch roofs, curved roofs and domes, the wind exposure factor, C_w , shall be as prescribed in Table 4.1.6.10.

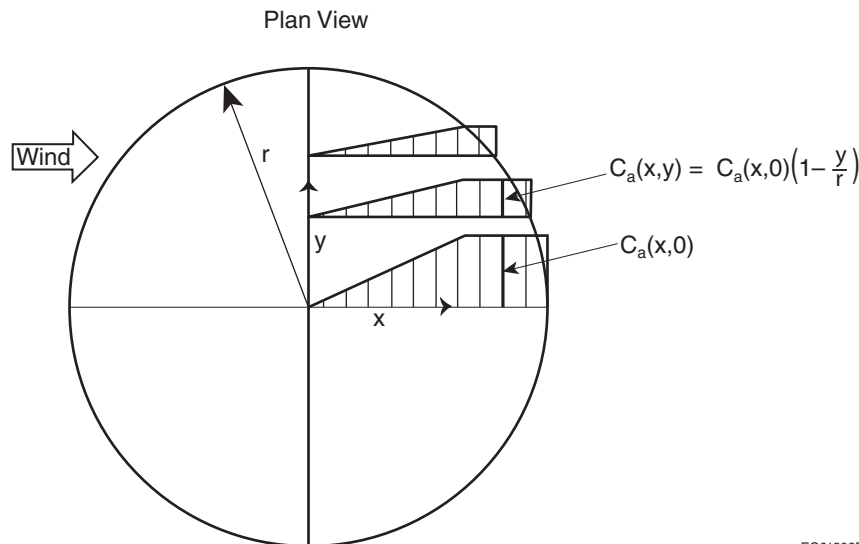

EG01308B

Figure 4.1.6.10.-B
Unbalanced snow accumulation factor on a circular dome
 Forming Part of Sentence 4.1.6.10.(7)

Notes to Figure 4.1.6.10.-B:

- Refer to Table 4.1.6.10. for applicable values of C_w and Sentences 4.1.6.2.(5) and (6) for applicable values of C_s .
- Refer to Sentences 4.1.6.10.(3) and (4) for the calculation of $C_a(x, 0)$.

4.1.6.11. Snow Loads Due to Sliding

1) Except as provided in Sentence (2), where an upper roof, or part thereof, slopes downwards with a slope $\alpha > 0$ towards a lower roof, the snow load, S , on the lower roof, determined in accordance with Articles 4.1.6.2. and 4.1.6.5., shall be augmented in accordance with Sentence (3) to account for the additional load resulting from sliding snow.

2) Sentence (1) need not apply where

- snow from the upper roof is prevented from sliding by a parapet or other effective means, or
- the upper roof is not considered slippery and has a slope of less than 20° .

- 3) The total weight of additional snow resulting from sliding shall be taken as half the total weight of snow resulting from the uniform load case prescribed in Article 4.1.6.2. with
- the accumulation factor $C_a = 1.0$ for the relevant part of the upper roof,
 - the slope factor, C_s , based on the slope of the lower roof, as prescribed in Sentences 4.1.6.2.(5) and (6), and
 - the sliding snow distributed on the lower roof such that it is a maximum for $x = 0$ and decreases linearly to 0 at $x = x_d$, as shown in Figure 4.1.6.11., where x and x_d are as defined in Article 4.1.6.5.

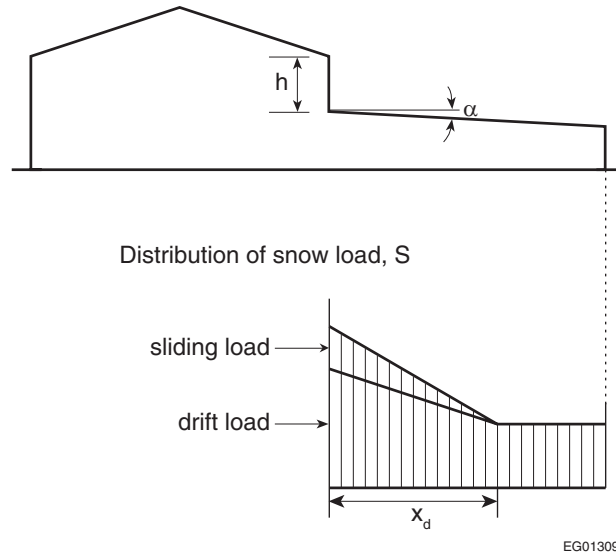

Figure 4.1.6.11.
Snow distribution on lower roof with sloped upper roof
 Forming Part of Sentence 4.1.6.11.(3)

4.1.6.12. Valleys in Curved or Sloped Roofs

- For valleys in curved or sloped roofs with a slope $\alpha > 10^\circ$, in addition to the full and partial load cases defined in Article 4.1.6.3., the non-uniform load cases II and III presented in Sentences (2) and (3) shall be considered to account for sliding, creeping and movement of meltwater.
- For case II (See Figure 4.1.6.12.), the accumulation factor, C_a , shall be calculated as follows:

$$C_a = \frac{1}{C_b} \text{ for } 0 < x \leq b/4, \text{ and}$$

$$C_a = \frac{0.5}{C_b} \text{ for } b/4 < x \leq b/2$$

where

- x = horizontal distance from the bottom of the valley, and
- b = twice the horizontal distance between the bottom of the valley and the peak of the roof surface in question.

- For case III (See Figure 4.1.6.12.), C_a shall be calculated as follows:

$$C_a = \frac{1.5}{C_b} \text{ for } 0 < x \leq b/8, \text{ and}$$

$$C_a = \frac{0.5}{C_b} \text{ for } b/8 < x \leq b/2$$

where

- x, b = as specified in Sentence (2).

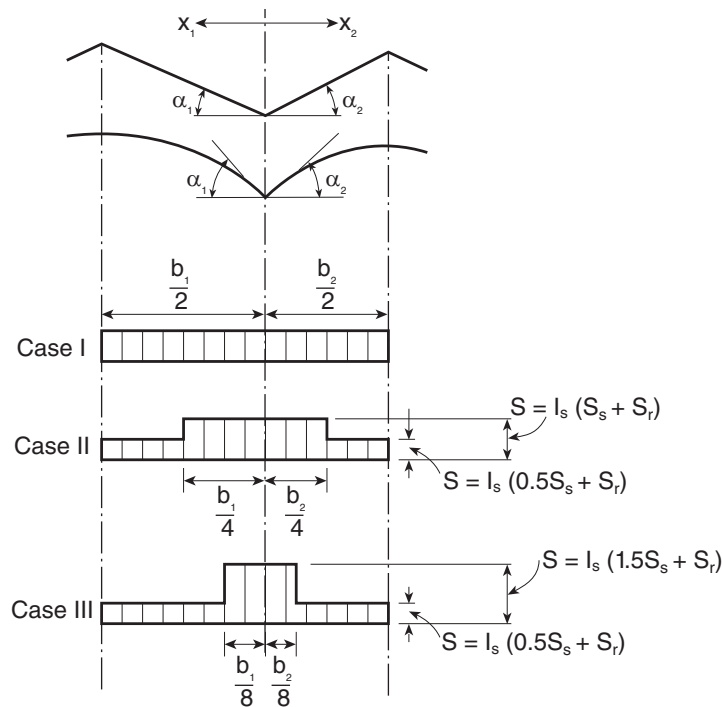

EG01310A

Figure 4.1.6.12.
Snow loads in valleys of sloped or curved roofs
 Forming Part of Sentences 4.1.6.12.(2) and (3)

Notes to Figure 4.1.6.12.:

- (1) $C_w = 1$, as per Sentence 4.1.6.2.(3).
- (2) $C_s = 1$, as per Sentence 4.1.6.2.(7).

4.1.6.13. Specific Weight of Snow

- 1) For the purposes of calculating snow loads in drifts, the specific weight of snow, γ , shall be taken as 4.0 kN/m^3 or $0.43S_s + 2.2 \text{ kN/m}^3$, whichever is lesser.

4.1.6.14. Snow Removal

- 1) Snow removal by mechanical, thermal, manual or other means shall not be used as a rationale to reduce design snow loads.

4.1.6.15. Ice Loading of Structures

- 1) For lattice structures connected to the *building*, and other *building* components or appurtenances involving small width elements subject to significant ice accretion, the weight of ice accretion and the effective area presented to wind shall be as prescribed in CSA S37, "Antennas, Towers, and Antenna-Supporting Structures."

4.1.7. Wind Load

4.1.7.1. Specified Wind Load

- 1) The specified wind loads for a *building* and its components shall be determined using the Static, Dynamic or Wind Tunnel Procedure as stated in Sentences (2) to (5).
- 2) For the design of *buildings* that are not dynamically sensitive, as defined in Sentence 4.1.7.2.(1), one of the following procedures shall be used to determine the specified wind loads:
 - a) the Static Procedure described in Article 4.1.7.3.,
 - b) the Dynamic Procedure described in Article 4.1.7.8., or
 - c) the Wind Tunnel Procedure described in Article 4.1.7.12.

- 3)** For the design of *buildings* that are dynamically sensitive, as defined in Sentence 4.1.7.2.(2), one of the following procedures shall be used to determine the specified wind loads:
- the Dynamic Procedure described in Article 4.1.7.8., or
 - the Wind Tunnel Procedure described in Article 4.1.7.12.
- 4)** For the design of *buildings* that may be subject to wake buffeting or channelling effects from nearby *buildings*, or that are very dynamically sensitive, as defined in Sentence 4.1.7.2.(3), the Wind Tunnel Procedure described in Article 4.1.7.12., shall be used to determine the specified wind loads.
- 5)** For the design of cladding and secondary structural members, one of the following procedures shall be used to determine the specified wind loads:
- the Static Procedure described in Article 4.1.7.3., or
 - the Wind Tunnel Procedure described in Article 4.1.7.12.
- 6)** Computational fluid dynamics shall not be used to determine the specified wind loads for a *building* and its components. (See Note A-4.1.7.1.(6).)

4.1.7.2. Classification of Buildings

- 1)** Except as provided in Sentences (2) and (3), a *building* is permitted to be classified as not dynamically sensitive. (See Note A-4.1.7.2.(1) and (2).)
- 2)** A *building* shall be classified as dynamically sensitive if
- its lowest natural frequency is less than 1 Hz and greater than 0.25 Hz,
 - its height is greater than 60 m, or
 - its height is greater than 4 times its minimum effective width, where the effective width, w , of a *building* shall be taken as

$$w = \frac{\sum h_i w_i}{\sum h_i}$$

where the summations are over the height of the *building* for a given wind direction, h_i is the height above *grade* to level i , and w_i is the width normal to the wind direction at height h_i ; the minimum effective width is the lowest value of the effective width considering all wind directions.

(See Note A-4.1.7.2.(1) and (2).)

- 3)** A *building* shall be classified as very dynamically sensitive if
- its lowest natural frequency is less than or equal to 0.25 Hz, or
 - its height is more than 6 times its minimum effective width as defined in Clause (2)(c).

4.1.7.3. Static Procedure

- 1)** The specified external pressure or suction due to wind on part or all of a surface of a *building* shall be calculated as follows:

$$p = I_W q C_e C_t C_g C_p$$

where

- p = specified external pressure acting statically and in a direction normal to the surface, considered positive when the pressure acts towards the surface and negative when it acts away from the surface,
- I_W = importance factor for wind load, as provided in Table 4.1.7.3.,
- q = reference velocity pressure, as provided in Sentence (4),
- C_e = exposure factor, as provided in Sentences (5) and (7),
- C_t = topographic factor, as provided in Article 4.1.7.4.,
- C_g = gust effect factor, as provided in Sentence (8), and
- C_p = external pressure coefficient, as provided in Articles 4.1.7.5. and 4.1.7.6.

Table 4.1.7.3.
Importance Factor for Wind Load, I_W
 Forming Part of Sentences 4.1.7.3.(1) and (3)

Importance Category	Importance Factor, I_W	
	ULS	SLS
Low	0.8	0.75
Normal	1	0.75
High	1.15	0.75
Post-disaster	1.25	0.75

2) The net wind load for the *building* as a whole shall be the algebraic difference of the loads on the windward and leeward surfaces, and in some cases, may be calculated as the sum of the products of the external pressures or suctions and the areas of the surfaces over which they are averaged as provided in Sentence (1).

3) The net specified pressure due to wind on part or all of a surface of a *building* shall be the algebraic difference, such as to produce the most critical effect, of the external pressure or suction calculated in accordance with Sentence (1) and the specified internal pressure or suction due to wind calculated as follows:

$$p_i = I_W q C_{ei} C_t C_{gi} C_{pi}$$

where

p_i = specified internal pressure acting statically and in a direction normal to the surface, either as a pressure directed towards the surface or as a suction directed away from the surface,

I_W, q, C_t = as defined in Sentence (1),

C_{ei} = exposure factor for internal pressure, as provided in Sentence (7),

C_{gi} = internal gust effect factor, as provided in Sentence (10), and

C_{pi} = internal pressure coefficient, as provided in Article 4.1.7.7.

4) The reference velocity pressure, q , shall be the appropriate value determined in conformance with Subsection 1.1.3., based on a probability of being exceeded in any one year of 1 in 50.

5) The exposure factor, C_e , shall be based on the reference height, h , determined in accordance with Sentence (6), for the surface or part of the surface under consideration and shall be

- $(h/10)^{0.2}$ but not less than 0.9 for open terrain, where open terrain is level terrain with only scattered *buildings*, trees or other obstructions, open water or shorelines thereof,
- $0.7(h/12)^{0.3}$ but not less than 0.7 for rough terrain, where rough terrain is suburban, urban or wooded terrain extending upwind from the *building* uninterrupted for at least 1 km or 20 times the height of the *building*, whichever is greater, or
- an intermediate value between the two exposures defined in Clauses (a) and (b) in cases where the site is less than 1 km or 20 times the height of the *building* from a change in terrain conditions, whichever is greater, provided an appropriate interpolation method is used. (See Note A-4.1.7.3.(5)(c).)

6) The reference height, h , shall be determined as follows:

- for *buildings* whose height is less than or equal to 20 m and less than the smaller plan dimension, h shall be the mid-height of the roof above *grade*, but not less than 6 m,
- for other *buildings*, h shall be
 - the actual height above *grade* of the point on the windward wall for which external pressures are being calculated,
 - the mid-height of the roof for pressures on surfaces parallel to the wind direction, and
 - the mid-height of the *building* for pressures on the leeward wall, and
- for any structural element exposed to wind, h shall be the mid-height of the element above the ground.

- 7) The exposure factor for internal pressures, C_{ei} , shall be determined as follows:
- for *buildings* whose height is greater than 20 m and that have a dominant opening, C_{ei} shall be equal to the exposure factor for external pressures, C_e , calculated at the mid-height of the dominant opening, and
 - for other *buildings*, C_{ei} shall be the same as the exposure factor for external pressures, C_e , calculated for a reference height, h , equal to the mid-height of the *building* or 6 m, whichever is greater.
- 8) Except as provided in Sentences (9) and 4.1.7.6.(1), the gust effect factor, C_g , shall be one of the following values:
- 2.0 for the *building* as a whole and main structural members, or
 - 2.5 for external pressures and suctions on secondary structural members, including cladding.
- 9) For cases where C_g and C_p are combined into a single product, $C_p C_g$, the values of C_p and C_g need not be independently specified. (See Article 4.1.7.6.)
- 10) The internal gust effect factor, C_{gi} , shall be 2.0, except it is permitted to be calculated using the following equation for large structures enclosing a single large unpartitioned volume that does not have numerous overhead doors or openings:

$$C_{gi} = 1 + \frac{1}{\sqrt{1 + \frac{V_0}{6950A}}}$$

where

V_0 = internal volume, in m^3 , and

A = total area of all exterior openings of the volume, in m^2 .

(See Note A-4.1.7.3.(10).)

4.1.7.4. Topographic Factor

- Except as provided in Sentence (2), the topographic factor, C_t , shall be taken as 1.0.
- For *buildings* on hills or escarpments with a slope, $H_h/(2L_h)$, greater than 0.1 (See Figure 4.1.7.4.), the topographic factor, C_t , shall be calculated as follows:

$$C_t = \left(1 + \frac{\Delta S}{C_g}\right) (1 + \Delta S)$$

where

$$\Delta S = \Delta S_{\max} \left(1 - \frac{|x|}{kL_h}\right) \exp(-\alpha z/L_h)$$

where

ΔS_{\max} = applicable value from Table 4.1.7.4.,

x = horizontal distance from the peak of the hill or escarpment,

L_h = horizontal distance upwind from the peak to the point where the ground surface lies at half the height of the hill or escarpment, or $2H_h$ (where H_h = height of hill or escarpment), whichever is greater,

z = height above ground, and

k and α = applicable constants from Table 4.1.7.4. based on shape of hill or escarpment.

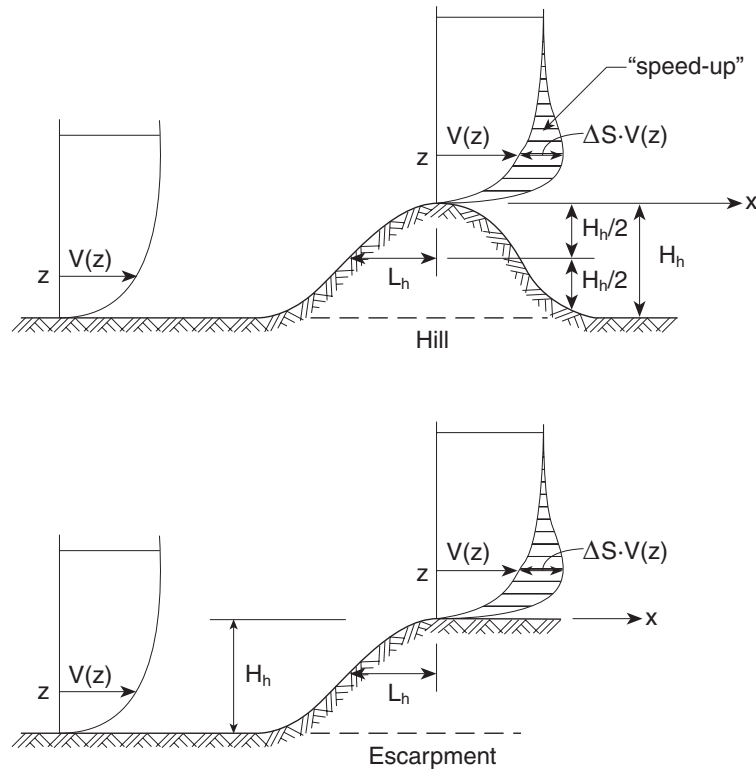

EG00915C

Figure 4.1.7.4.
Speed-up of mean velocity on a hill or escarpment
 Forming Part of Sentence 4.1.7.4.(2)

Note to Figure 4.1.7.4.:
 (1) $V(z)$ = wind speed

Table 4.1.7.4.
Parameters for Maximum Speed-up Over Hills and Escarpments
 Forming Part of Sentence 4.1.7.4.(2)

Shape of Hill or Escarpment	$\Delta S_{max}^{(1)}$	α	k	
			$x < 0$	$x \geq 0$
2-dimensional hill	$2.2 H_h/L_h$	3	1.5	1.5
2-dimensional escarpment	$1.3 H_h/L_h$	2.5	1.5	4
3-dimensional axi-symmetrical hill	$1.6 H_h/L_h$	4	1.5	1.5

Notes to Table 4.1.7.4.:

(1) For $H_h/L_h > 0.5$, assume $H_h/L_h = 0.5$ and substitute $2 H_h$ for L_h in the equation for ΔS .

4.1.7.5. External Pressure Coefficients

- 1) Applicable values of external pressure coefficients, C_p , are provided in
 - a) Sentences (2) to (5), and
 - b) Article 4.1.7.6. for certain shapes of low *buildings*.

2) For the design of the main structural system, the value of C_p shall be established as follows, where H is the height of the *building* and D is the width of the *building* parallel to the wind direction:

- a) on the windward face,
 - $C_p = 0.6$ for $H/D < 0.25$
 - $= 0.27(H/D + 2)$ for $0.25 \leq H/D < 1.0$, and
 - $= 0.8$ for $H/D \geq 1.0$,
- b) on the leeward face,
 - $C_p = -0.3$ for $H/D < 0.25$,
 - $= -0.27(H/D + 0.88)$ for $0.25 \leq H/D < 1.0$, and
 - $= -0.5$ for $H/D \geq 1.0$, and
- c) on the walls parallel to the wind, $C_p = -0.7$.

(See Note A-4.1.7.5.(2) and (3).)

3) For the design of roofs, the value of C_p shall be established as follows, where x is the distance from the upwind edge of the roof:

- a) for $H/D \geq 1.0$, $C_p = -1.0$, and
- b) for $H/D < 1.0$,
 - $C_p = -1.0$ for $x \leq H$, and
 - $= -0.5$ for $x > H$.

(See Note A-4.1.7.5.(2) and (3).)

4) For the design of the cladding and of secondary structural elements supporting the cladding, the value of C_p shall be established as follows, where W and D are the widths of the *building*:

- a) on walls, C_p shall be taken as ± 0.9 , except that within a distance equal to the larger of $0.1D$ and $0.1W$ from a *building* corner, the negative value of C_p shall be taken as -1.2 ,
- b) on walls where vertical ribs deeper than 1 m are placed on the facade, C_p shall be taken as ± 0.9 , except that, within a distance equal to the larger of $0.2D$ and $0.2W$ from a *building* corner, the negative value of C_p shall be taken as -1.4 , and
- c) on roofs, C_p shall be taken as -1.0 , except that
 - i) within a distance equal to the larger of $0.1D$ and $0.1W$ from a roof edge, C_p shall be taken as -1.5 ,
 - ii) in a zone that is within a distance equal to the larger of $0.2W$ and $0.2D$ from a roof corner, C_p shall be taken as -2.3 but is permitted to be taken as -2.0 for roofs with perimeter parapets that are higher than 1 m, and
 - iii) on lower levels of flat stepped roofs, positive pressure coefficients established for the walls of the steps apply for a distance b (See Figure 4.1.7.6.-D for the definition of b).

(See Note A-4.1.7.5.(4).)

5) For the design of balcony *guards*, the internal pressure coefficient, C_{pi} , shall be taken as zero and the value of C_p shall be taken as ± 0.9 , except that within a distance equal to the larger of $0.1W$ and $0.1D$ from a *building* corner, C_p shall be taken as ± 1.2 .

4.1.7.6. External Pressure Coefficients for Low Buildings

1) For the design of *buildings* with a height, H , that is both less than or equal to 20 m and less than the smaller plan dimension, the values of the product of the pressure coefficient and gust factor, $C_p C_g$, provided in Sentences (2) to (9) are permitted to be used.

2) For the design of the main structural system of the *building*, which is affected by wind pressures on more than one surface, the values of $C_p C_g$ are provided in Figure 4.1.7.6.-A.

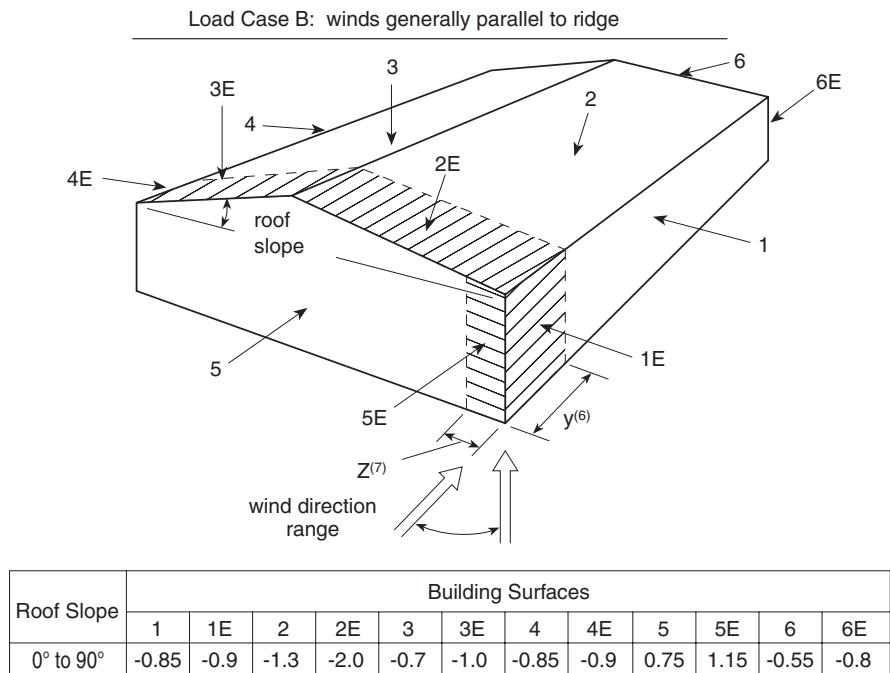
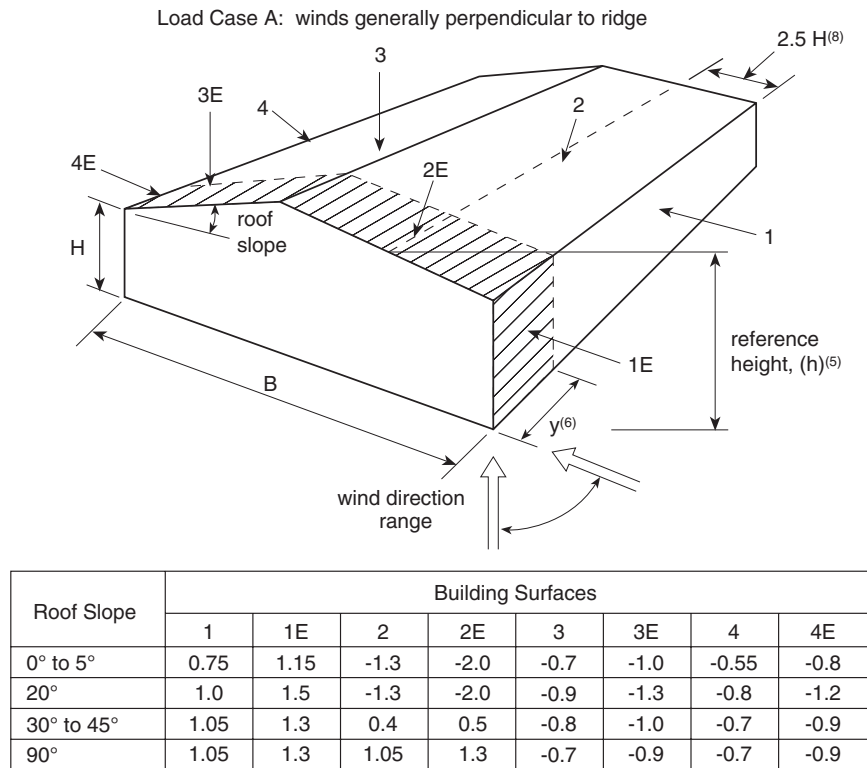

EG00920B

Figure 4.1.7.6.-A
External peak values of $C_p C_g$ for primary structural actions arising from wind load acting simultaneously on all surfaces of low buildings ($H \leq 20$ m)
 Forming Part of Sentence 4.1.7.6.(2)

Notes to Figure 4.1.7.6.-A:

- (1) The *building* must be designed for all wind directions. Each corner must be considered in turn as the windward corner shown in the sketches. For all roof slopes, Load Case A and Load Case B are required as two separate loading conditions to generate the wind actions, including torsion, to be resisted by the structural system.
- (2) For values of roof slope not shown, the coefficient ($C_p C_g$) can be interpolated linearly.

- (3) Positive coefficients denote forces toward the surface, whereas negative coefficients denote forces away from the surface.
- (4) For the design of *foundations*, exclusive of anchorages to the frame, only 70% of the effective load is to be considered.
- (5) The reference height, h , for pressures is the mid-height of the roof or 6 m, whichever is greater. The eave height, H , may be substituted for the mid-height of the roof if the roof slope is less than 7° .
- (6) End-zone width y should be the greater of 6 m or $2z$, where z is the width of the gable-wall end zone defined for Load Case B below. Alternatively, for *buildings* with frames, the end zone y may be the distance between the end and the first interior frame.
- (7) End-zone width z is the lesser of 10% of the least horizontal dimension and 40% of height, H , but not less than 4% of the least horizontal dimension or 1 m.
- (8) For $B/H > 5$ in Load Case A, the listed negative coefficients on surfaces 2 and 2E should only be applied on an area whose width is $2.5H$ measured from the windward eave. The pressures on the remainder of the windward roof should be reduced to the pressures for the leeward roof.
- 3)** For the design of individual walls and wall cladding, the values of $C_p C_g$ are provided in Figure 4.1.7.6.-B.
- 4)** For the design of roofs with a slope less than or equal to 7° , the values of $C_p C_g$ are provided in Figure 4.1.7.6.-C.
- 5)** For the design of flat roofs with steps in elevation, the values of $C_p C_g$ are provided in Figure 4.1.7.6.-D.
- 6)** For the design of gabled or hipped, single-ridge roofs with a slope greater than 7° , the values of $C_p C_g$ are provided in Figure 4.1.7.6.-E.
- 7)** For the design of gabled, multi-ridge roofs, the values of $C_p C_g$ are provided in
- Figure 4.1.7.6.-C for roofs with a slope less than or equal to 10° , and
 - Figure 4.1.7.6.-F for roofs with a slope greater than 10° .
- 8)** For monosloped roofs, the values of $C_p C_g$ are provided in
- Figure 4.1.7.6.-C for roofs with a slope less than or equal to 3° , and
 - Figure 4.1.7.6.-G for roofs with a slope greater than 3° and less than or equal to 30° .
- 9)** For sawtooth roofs, the values of $C_p C_g$ are provided in
- Figure 4.1.7.6.-C for roofs with a slope less than or equal to 10° , and
 - Figure 4.1.7.6.-H for roofs with a slope greater than 10° .

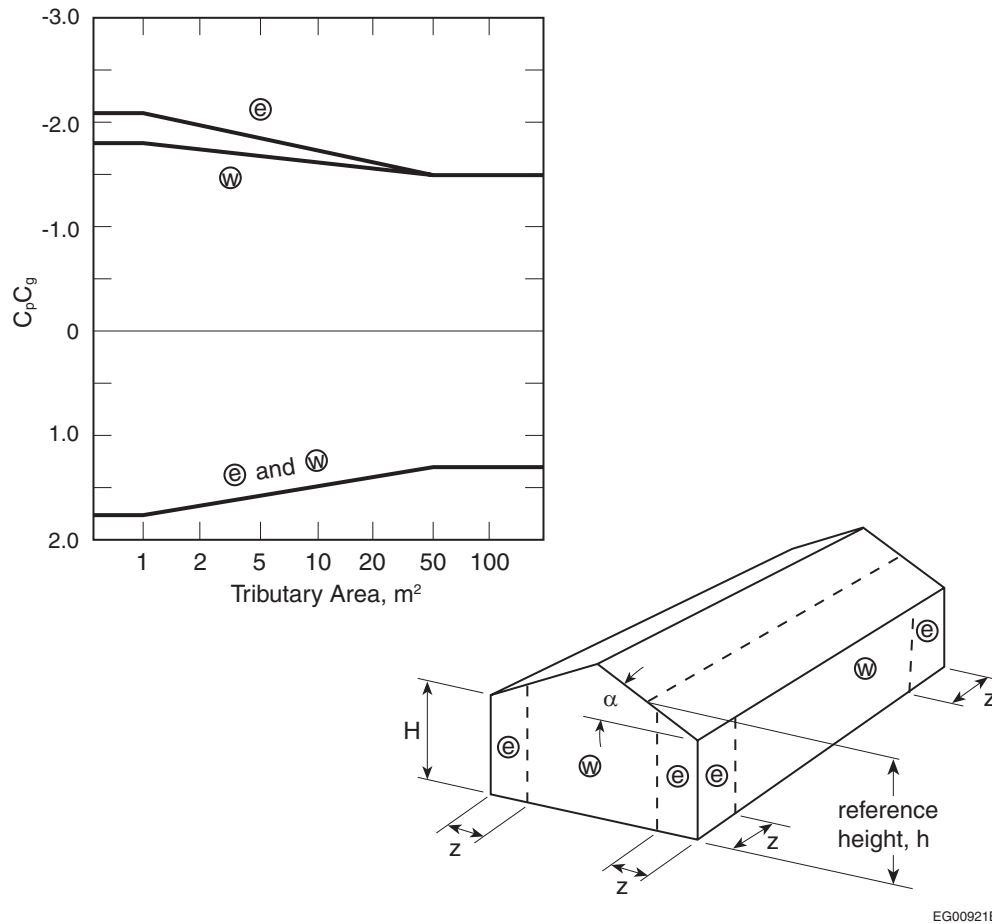
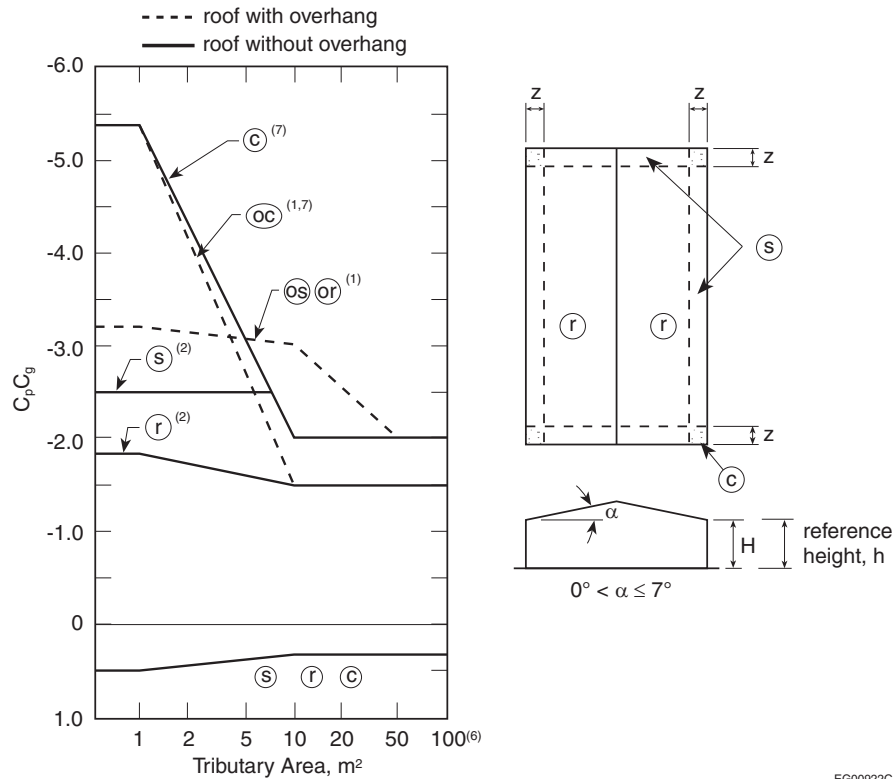

Figure 4.1.7.6.-B
External peak values of $C_p C_g$ on individual walls for the design of cladding and secondary structural members
 Forming Part of Sentence 4.1.7.6.(3)

Notes to Figure 4.1.7.6.-B:

- (1) These coefficients apply for any roof slope, α .
- (2) End-zone width z is the lesser of 10% of the least horizontal dimension and 40% of height, H , but not less than 4% of the least horizontal dimension or 1 m.
- (3) Combinations of external and internal pressures must be evaluated to obtain the most severe loading.
- (4) Positive coefficients denote forces toward the surface, whereas negative coefficients denote forces away from the surface. Each structural element must be designed to withstand forces of both signs.
- (5) Pressure coefficients generally apply for facades with architectural features; however, where vertical ribs deeper than 1 m are placed on a facade, a local $C_p C_g$ of -2.8 applies to zone e.



EG00922C

Figure 4.1.7.6.-C
External peak values of C_pC_g on roofs with a slope of 7° or less for the design of structural components and cladding
 Forming Part of Sentences 4.1.7.6.(4), (7), (8) and (9)

Notes to Figure 4.1.7.6.-C:

- (1) Coefficients for overhung roofs have the prefix “o” and refer to the same roof areas as referred to by the corresponding symbol without a prefix. They include contributions from both upper and lower surfaces. In the case of overhangs, the walls are inboard of the roof outline.
- (2) s and r apply to both roofs and upper surfaces of canopies.
- (3) End-zone width z is the lesser of 10% of the least horizontal dimension and 40% of height, H, but not less than 4% of the least horizontal dimension or 1 m.
- (4) Combinations of external and internal pressures must be evaluated to obtain the most severe loading.
- (5) Positive coefficients denote forces toward the surface, whereas negative coefficients denote forces away from the surface. Each structural element must be designed to withstand forces of both signs.
- (6) For calculating the uplift forces on tributary areas larger than 100 m^2 on unobstructed nearly-flat roofs with low parapets, and where the centre of the tributary area is at least twice the height of the *building* from the nearest edge, the value of C_pC_g may be reduced from -1.5 to -1.1 at $x/H = 2$ and further reduced linearly to -0.6 at $x/H = 5$, where x is the distance to the nearest edge and H is the height of the *building*.
- (7) For roofs having a perimeter parapet with a height of 1 m or greater, the corner coefficients C_pC_g for tributary areas less than 1 m^2 can be reduced from -5.4 to -4.4 .

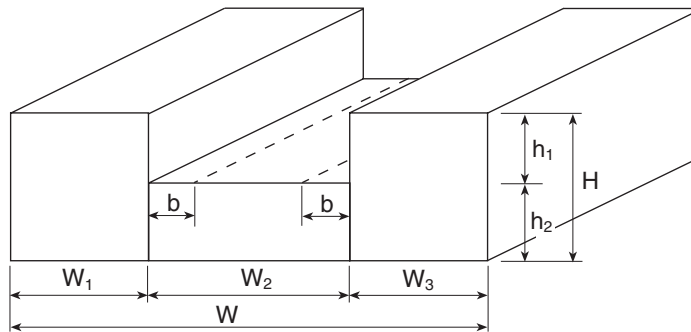
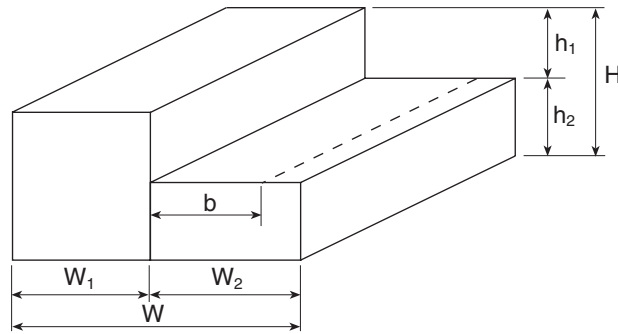

EG00923A

Figure 4.1.7.6.-D**External peak values of $C_p C_g$ for the design of the structural components and cladding of buildings with stepped roofs**

Forming Part of Sentence 4.1.7.6.(5)

Notes to Figure 4.1.7.6.-D:

- (1) The zone designations, pressure-gust coefficients and notes provided in Figure 4.1.7.6.-C apply on both the upper and lower levels of flat stepped roofs, except that on the lower levels, positive pressure-gust coefficients equal to those in Figure 4.1.7.6.-B for walls apply for a distance, b , where b is equal to $1.5h_1$ but not greater than 30 m. For all walls in Figure 4.1.7.6.-D, zone designations and pressure coefficients provided for walls in Figure 4.1.7.6.-B apply.
- (2) Note (1) above applies only when the following conditions are met: $h_1 \geq 0.3H$, $h_1 \geq 3$ m, and W_1 , W_2 , or W_3 is greater than $0.25W$ but not greater than $0.75W$.

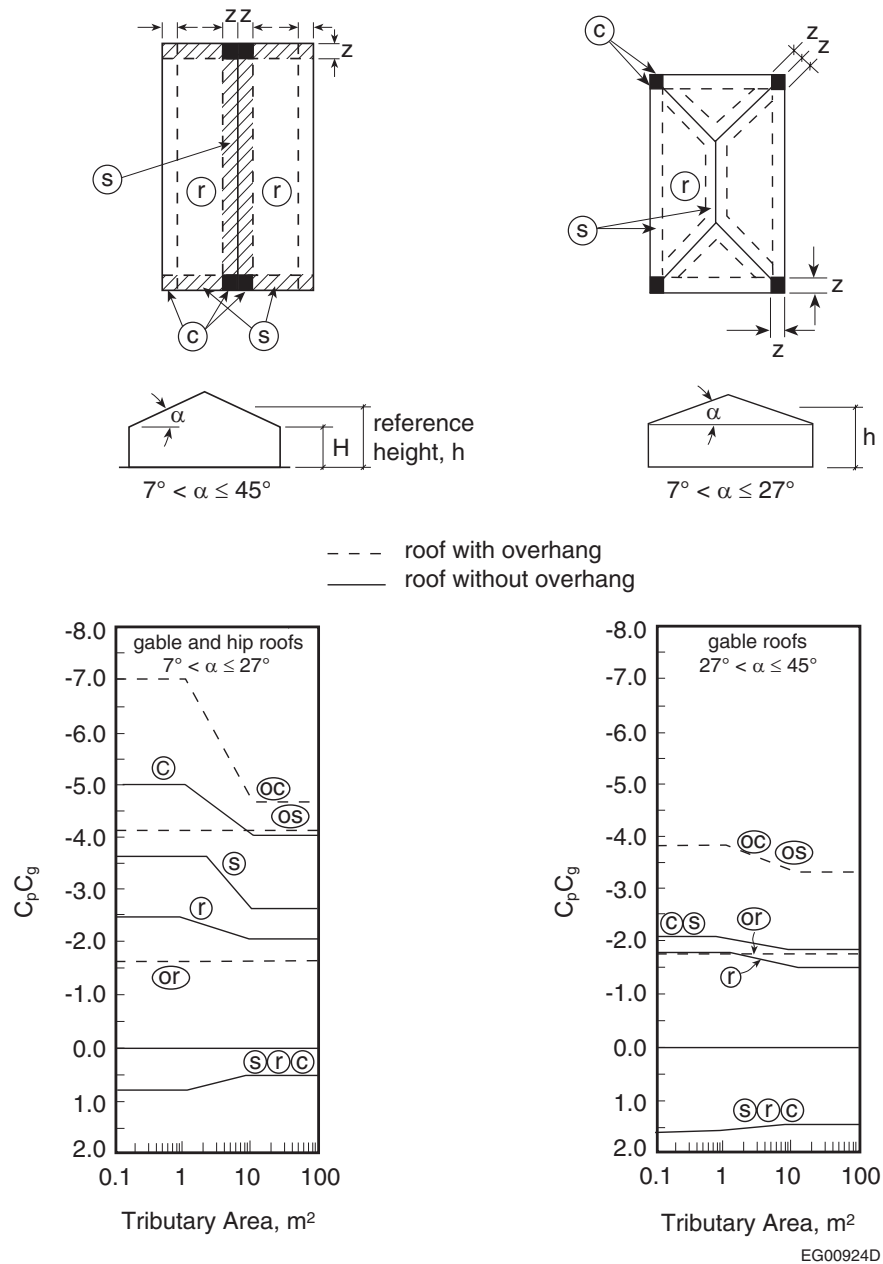

EG00924D

Figure 4.1.7.6.-E
External peak values of $C_p C_g$ on single-span gabled and hipped roofs with a slope greater than 7° for the design of structural components and cladding
 Forming Part of Sentence 4.1.7.6.(6)

Notes to Figure 4.1.7.6.-E:

- (1) Coefficients for overhung roofs have the prefix "o" and refer to the same roof areas as referred to by the corresponding symbol without a prefix. They include contributions from both upper and lower surfaces.
- (2) End-zone width z is the lesser of 10% of the least horizontal dimension and 40% of height, H , but not less than 4% of the least horizontal dimension or 1 m.
- (3) Combinations of external and internal pressures must be evaluated to obtain the most severe loading.
- (4) Positive coefficients denote forces towards the surface, whereas negative coefficients denote forces away from the surface. Each structural element must be designed to withstand forces of both signs.
- (5) For hipped roofs with $7^\circ < \alpha \leq 27^\circ$, edge/ridge strips and pressure-gust coefficients for ridges of gabled roofs apply along each hip.

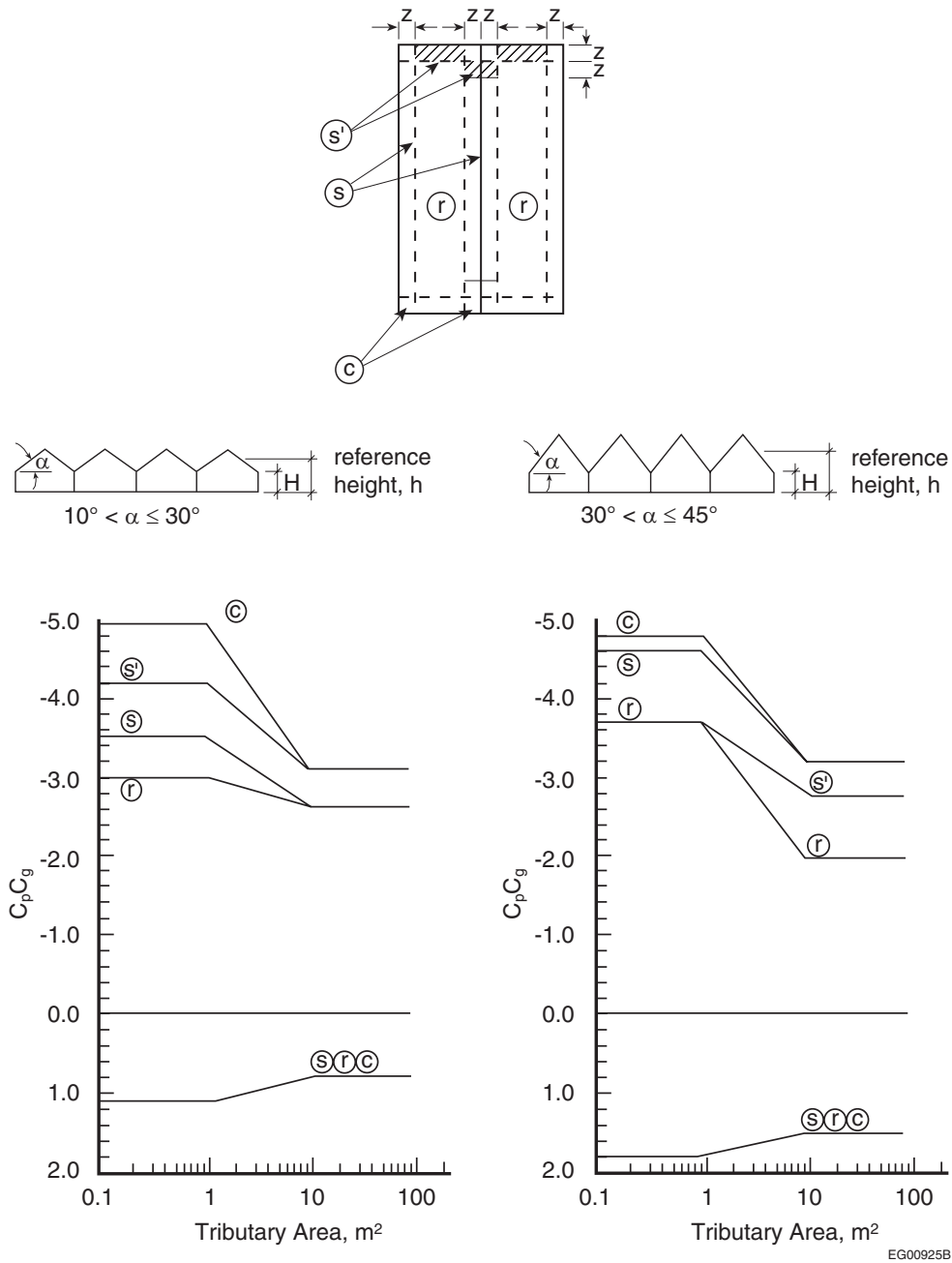
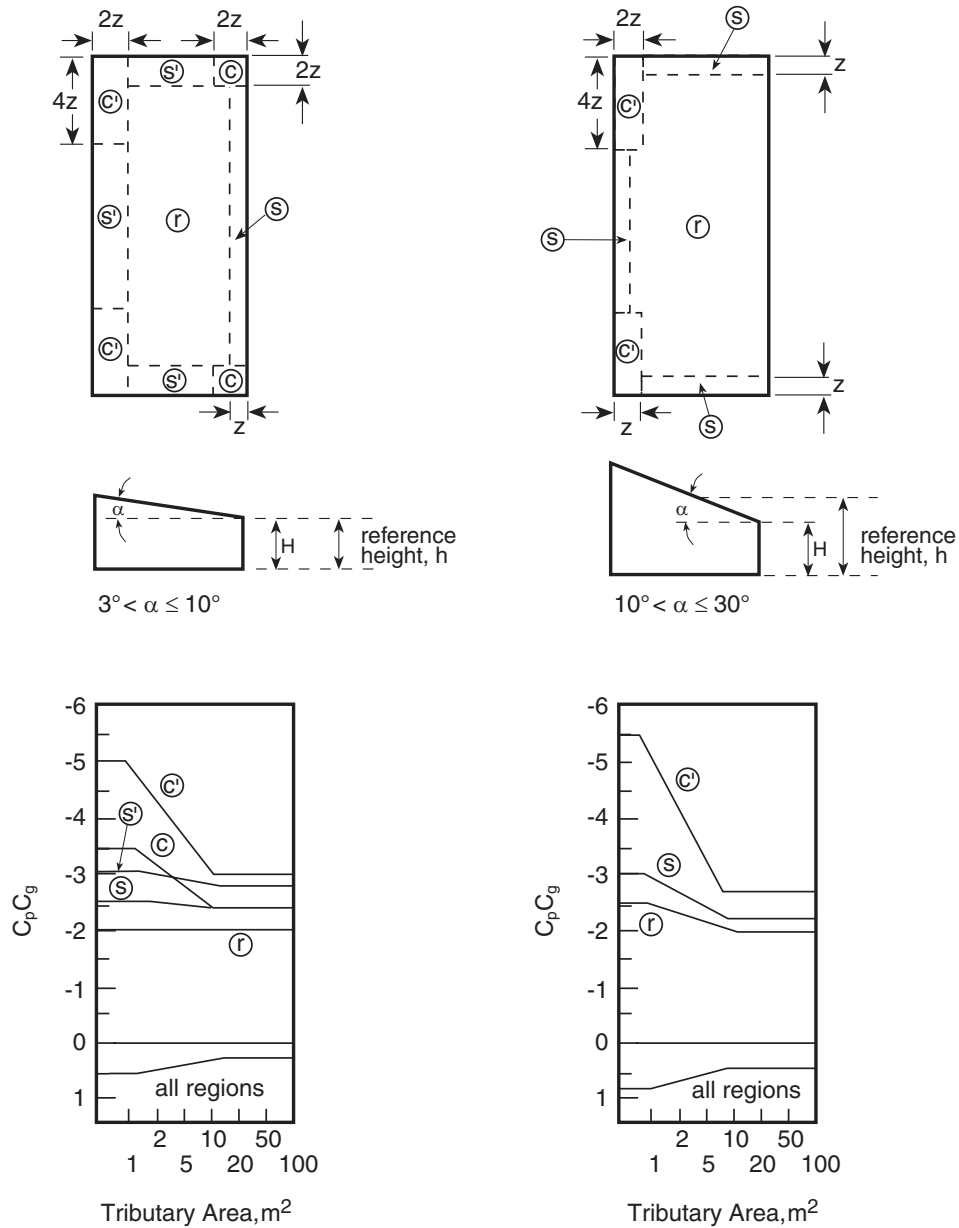

Figure 4.1.7.6.-F
External peak values of $C_p C_g$ on multi-span gabled (folded) roofs with a slope greater than 10° for the design of structural components and cladding
 Forming Part of Sentence 4.1.7.6.(7)

Notes to Figure 4.1.7.6.-F:

- (1) End-zone width z is the lesser of 10% of the least horizontal dimension and 40% of height, H , but not less than 4% of the least horizontal dimension or 1 m.
- (2) Combinations of external and internal pressures must be evaluated to obtain the most severe loading.
- (3) Positive coefficients denote forces towards the surface, whereas negative coefficients denote forces away from the surface. Each structural element must be designed to withstand forces of both signs.
- (4) For $\alpha \leq 10^\circ$, the coefficients given in Figure 4.1.7.6.-C apply, but for cases where $\alpha > 7^\circ$, use $\alpha = 7^\circ$.



EG00926B

Figure 4.1.7.6.-G
External peak values of $C_p C_g$ on monoslope roofs for the design of structural components and cladding
 Forming Part of Sentence 4.1.7.6.(8)

Notes to Figure 4.1.7.6.-G:

- (1) End-zone width z is the lesser of 10% of the least horizontal dimension and 40% of height, H , but not less than 4% of the least horizontal dimension or 1 m.
- (2) Combinations of external and internal pressures must be evaluated to obtain the most severe loading.
- (3) Positive coefficients denote forces towards the surface, whereas negative coefficients denote forces away from the surface. Each structural element must be designed to withstand forces of both signs.
- (4) For $\alpha \leq 3^\circ$, the coefficients given in Figure 4.1.7.6.-C apply.

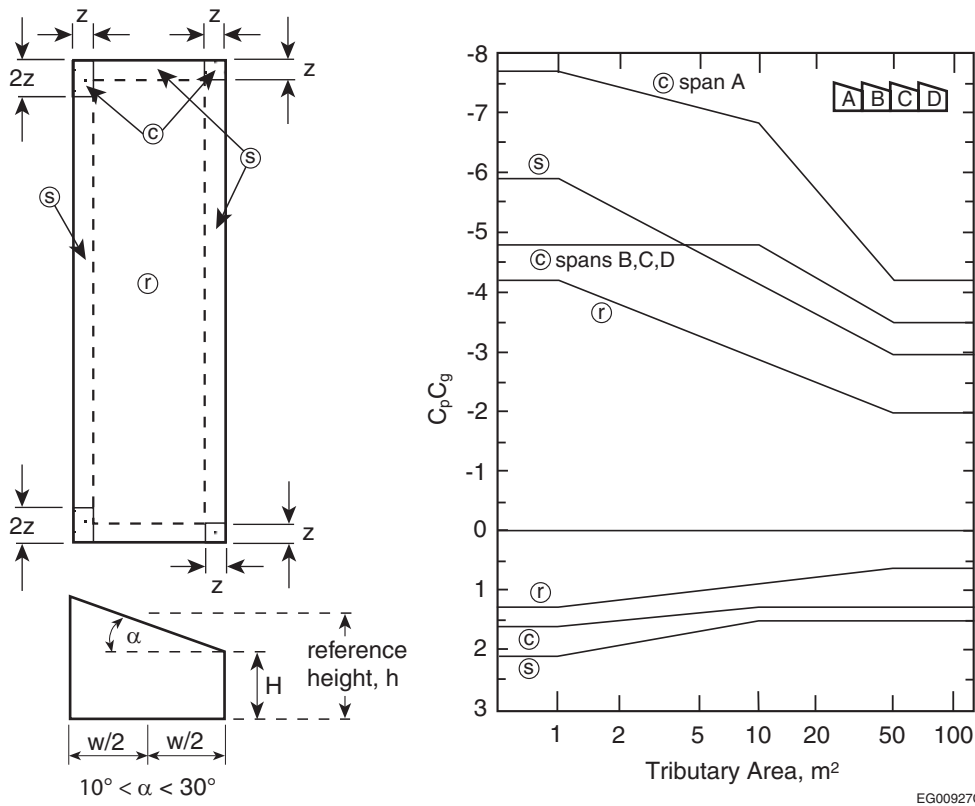

Figure 4.1.7.6.-H
External peak values of $C_p C_g$ on sawtooth roofs with a slope greater than 10° for the design of structural components and cladding
 Forming Part of Sentence 4.1.7.6.(9)

Notes to Figure 4.1.7.6.-H:

- (1) End-zone width z is the lesser of 10% of the least horizontal dimension and 40% of height, H , but not less than 4% of the least horizontal dimension or 1 m.
- (2) Combinations of external and internal pressures must be evaluated to obtain the most severe loading.
- (3) Positive coefficients denote forces towards the surface, whereas negative coefficients denote forces away from the surface. Each structural element must be designed to withstand forces of both signs.
- (4) Negative coefficients on the corner zones of Span A differ from those on Spans B, C, and D.
- (5) For $\alpha \leq 10^\circ$, the coefficients given in Figure 4.1.7.6.-C apply, but for cases where $\alpha > 7^\circ$, use $\alpha = 7^\circ$.

4.1.7.7. Internal Pressure Coefficient

- 1) The internal pressure coefficient, C_{pi} , shall be as prescribed in Table 4.1.7.7.

Table 4.1.7.7.
Internal Pressure Coefficients
 Forming Part of Sentence 4.1.7.7.(1)

Building Openings	Values for C_{pi}
Uniformly distributed small openings amounting to less than 0.1% of the total surface area of the building	-0.15 to 0.0
Non-uniformly distributed openings of which none is significant or significant openings that are wind-resistant and closed during storms	-0.45 to +0.30
Large openings likely to remain open during storms	-0.70 to +0.70

4.1.7.8. Dynamic Procedure

1) For the application of the Dynamic Procedure, the provisions of Article 4.1.7.3. shall be followed, except that the exposure factor, C_e , shall be as prescribed in Sentences (2) and (3), and the gust effect factor, C_g , shall be as prescribed in Sentence (4), when determining the wind loads on the main structural system.

2) For *buildings* in open terrain, as defined in Clause 4.1.7.3.(5)(a), the value of C_e for the design of the main structural system shall be calculated as follows:

$$C_e = \left(\frac{h}{10} \right)^{0.28}, \text{ but } 1.0 \leq C_e \leq 2.5$$

(See Note A-4.1.7.8.(2) and (3).)

3) For *buildings* in rough terrain, as defined in Clause 4.1.7.3.(5)(b), the value of C_e for the design of the main structural system shall be calculated as follows:

$$C_e = 0.5 \left(\frac{h}{12.7} \right)^{0.50}, \text{ but } 0.5 \leq C_e \leq 2.5$$

(See Note A-4.1.7.8.(2) and (3).)

4) For the design of the main structural system, C_g shall be calculated as follows:

$$C_g = 1 + g_p \frac{\sigma}{\mu}$$

where

$$g_p = \text{peak factor calculated as } \sqrt{2 \ln(\nu T)} + \frac{0.577}{\sqrt{2 \ln(\nu T)}}, \text{ and}$$

$$\sigma/\mu = \sqrt{\frac{K}{C_{eH}} \left(B + \frac{sF}{\beta} \right)},$$

where

$$\nu = \text{average fluctuation rate calculated as } f_{nD} \sqrt{\frac{sF}{sF + \beta B}},$$

$$T = 3\,600 \text{ s,}$$

$$K = 0.08 \text{ for open terrain and } 0.10 \text{ for rough terrain,}$$

$$C_{eH} = \text{exposure factor evaluated at reference height } h = H,$$

$$B = \text{background turbulence factor, a function of } w/H \text{ determined from Figure 4.1.7.8.,}$$

$$s = \text{size reduction factor calculated as } \frac{\pi}{3} \left[\frac{1}{1 + \frac{8f_n H}{3V_H}} \right] \left[\frac{1}{1 + \frac{10f_n w}{V_H}} \right],$$

$$F = \text{gust energy ratio calculated as } \frac{x_0^2}{(1+x_0^2)^{4/3}}, \text{ where } x_0 = (1\,220 f_n / V_H), \text{ and}$$

$$\beta = \text{damping ratio, which shall be determined by a rational method, or may be taken to be } 0.01 \text{ for steel structures, } 0.02 \text{ for concrete structures, and } 0.015 \text{ for composite structures,}$$

where

$$f_{nD} = \text{natural frequency of vibration of the } \textit{building} \text{ in the along-wind direction, in Hz,}$$

$$f_n = \text{lowest natural frequency of the } \textit{building}, \text{ in Hz, as defined in Sentences 4.1.7.2.(2) and (3),}$$

$$H = \text{height of the } \textit{building},$$

$$w = \text{effective width of windward face of the } \textit{building} \text{ calculated as } \frac{\sum h_i w_i}{\sum h_i}, \text{ where } w_i = \text{width normal to wind direction at height } h_i, \text{ and}$$

$$V_H = \text{mean wind speed at the top of the structure, in m/s, calculated as } \bar{V} \sqrt{C_{eH}},$$

where

$$\bar{V} = \text{reference wind speed at a height of } 10 \text{ m, in m/s, calculated as } \sqrt{\frac{2 \cdot I_W \cdot q}{\rho} C_{eH}},$$

where

$$I_W = \text{importance factor,}$$

$$q = \text{reference velocity pressure, in Pa, and}$$

$$\rho = \text{air density} = 1.2929 \text{ kg/m}^3.$$

(See Note A-4.1.7.8.(4).)

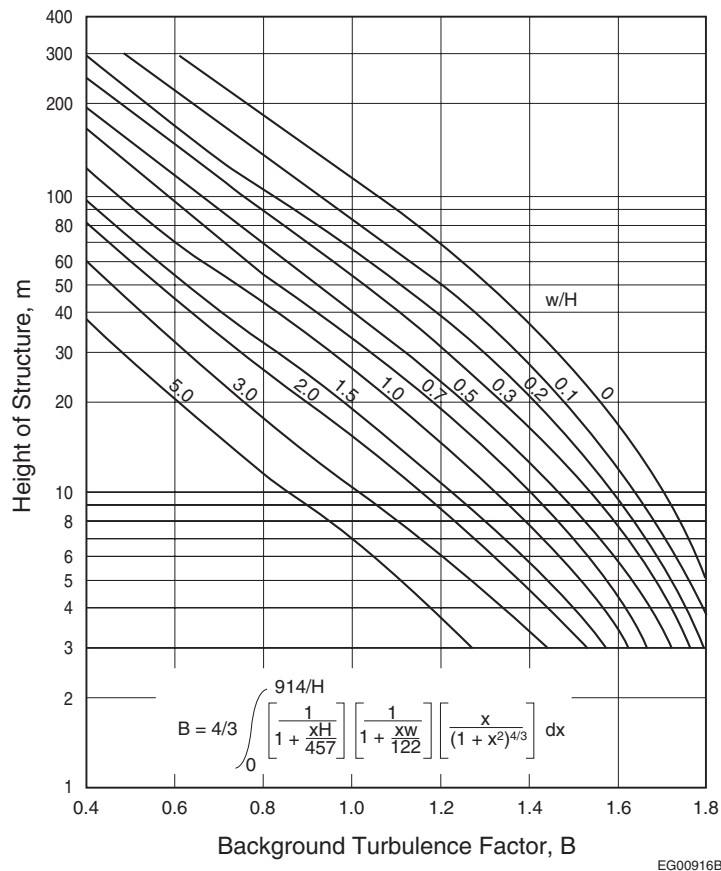

Figure 4.1.7.8.
Background turbulence factor, B
 Forming Part of Sentence 4.1.7.8.(4)

4.1.7.9. Full and Partial Wind Loading

1) Except where the wind loads are derived from the combined $C_p C_g$ values determined in accordance with Article 4.1.7.6., *buildings* and structural members shall be capable of withstanding the effects of the following loads:

- a) the full wind loads acting along each of the 2 principal horizontal axes considered separately,
- b) the wind loads described in Clause (a) but with 100% of the load removed from any one portion of the area,
- c) the wind loads described in Clause (a) but with both axes considered simultaneously at 75% of their full value, and
- d) the wind loads described in Clause (c) but with 50% of these loads removed from any portion of the area.

(See Note A-4.1.7.9.(1).)

4.1.7.10. Interior Walls and Partitions

1) In the design of interior walls and *partitions*, due consideration shall be given to differences in air pressure on opposite sides of the wall or *partition* which may result from

- a) pressure differences between the windward and leeward sides of a *building*,
- b) stack effects due to a difference in air temperature between the exterior and interior of the *building*, and
- c) air pressurization by the mechanical services of the *building*.

4.1.7.11. Exterior Ornamentations, Equipment and Appendages

(See Note A-4.1.7.11.)

- 1) The effects of wind loads on exterior ornamentations, equipment and appendages, including the increase in exposed area as a result of ice buildup as prescribed in CSA S37, “Antennas, Towers, and Antenna-Supporting Structures,” shall be considered in the structural design of the connections and the *building*.
- 2) Where there are a number of similar components, the net increase in force is permitted to be based on the total area for all similar components as opposed to the summation of forces of individual elements.

4.1.7.12. Wind Tunnel Procedure

- 1) Except as provided in Sentences (2) and (3), wind tunnel tests on scale models to determine wind loads on *buildings* shall be conducted in accordance with ASCE/SEI 49, “Wind Tunnel Testing for Buildings and Other Structures.”
- 2) Where an adjacent *building* provides substantial sheltering effect, the wind loads for the main structural system shall be no lower than 80% of the loads determined from tests referred to in Sentence (1) with the effect of the sheltering *building* removed as applied to
 - a) the base shear force for *buildings* with a ratio of height to minimum effective width, as defined in Sentence 4.1.7.2.(2), less than or equal to 1.0, or
 - b) the base moment for *buildings* with a ratio of height to minimum effective width greater than 1.0.
- 3) For the design of cladding and secondary structural members, the exterior wind loads determined from the wind tunnel tests shall be no less onerous than those determined by analysis in accordance with Article 4.1.7.3. using the following assumptions:
 - a) $C_p = \pm 0.72$ and $C_g = 2.5$, where the *building's* height is greater than 20 m or greater than its minimum effective width, and
 - b) $C_p C_g = 80\%$ of the values for zones w and r provided in Article 4.1.7.6., where the *building's* height is less than or equal to 20 m and no greater than its minimum effective width.

4.1.8. Earthquake Load and Effects

4.1.8.1. Analysis

- 1) Except as permitted in Sentence (2), the deflections and specified loading due to earthquake motions shall be determined according to the requirements of Articles 4.1.8.2. to 4.1.8.22.
- 2) Where $I_E F_s S_a(0.2)$ and $I_E F_s S_a(2.0)$ are less than 0.16 and 0.03 respectively, the deflections and specified loading due to earthquake motions are permitted to be determined in accordance with Sentences (3) to (15), where
 - a) I_E is the earthquake importance factor and has a value of 0.8, 1.0, 1.3 and 1.5 for *buildings* of Low, Normal, High and Post-Disaster importance respectively,
 - b) F_s is the site coefficient based on the average N_{60} or S_u , as defined in Article 4.1.8.2., for the top 30 m of *soil* below the footings, pile caps, or mat *foundations* and has a value of
 - i) 1.0 for *rock* sites or when $N_{60} > 50$ or $S_u > 100$ kPa,
 - ii) 1.6 when $15 \leq N_{60} \leq 50$ or $50 \text{ kPa} \leq S_u \leq 100$ kPa, and
 - iii) 2.8 for all other cases, and
 - c) $S_a(T)$ is the 5% damped spectral response acceleration value for period T, determined in accordance with Subsection 1.1.3.
- 3) The structure shall have a clearly defined
 - a) Seismic Force Resisting System (SFRS) to resist the earthquake loads and their effects, and
 - b) load path (or paths) that will transfer the inertial forces generated by the earthquake to the *foundations* and supporting ground.
- 4) An unreinforced masonry SFRS shall not be permitted where
 - a) I_E is greater than 1.0, or
 - b) the height above *grade* is greater than or equal to 30 m.

- 5)** The height above *grade* of SFRS designed in accordance with CSA S136, “North American Specification for the Design of Cold-Formed Steel Structural Members,” shall be less than 15 m.
- 6)** Earthquake forces shall be assumed to act horizontally and independently about any two orthogonal axes.
- 7)** The minimum lateral earthquake design force, V_s , at the base of the structure in the direction under consideration shall be calculated as follows:

$$V_s = F_s S_a (T_s) I_E W_t / R_s$$

where

$S_a(T_s)$ = value of S_a at T_s determined by linear interpolation between the value of S_a at 0.2 s, 0.5 s, and 1.0 s, and

= $S_a(0.2)$ for $T_s \leq 0.2$ s,

W_t = sum of W_i over the height of the *building*, where W_i is defined in Article 4.1.8.2., and

R_s = 1.5, except $R_s = 1.0$ for structures where the *storey* strength is less than that in the *storey* above and for an unreinforced masonry SFRS,

where

T_s = fundamental lateral period of vibration of the *building*, as defined in Article 4.1.8.2.,

= $0.085(h_n)^{3/4}$ for steel moment frames,

= $0.075(h_n)^{3/4}$ for concrete moment frames,

= 0.1 N for other moment frames,

= $0.025h_n$ for braced frames, and

= $0.05(h_n)^{3/4}$ for shear walls and other structures,

where

h_n = height above the base, in m, as defined in Article 4.1.8.2., except that V_s shall not be less than $F_s S_a(1.0) I_E W_t / R_s$ and, in cases where $R_s = 1.5$, V_s need not be greater than $F_s S_a(0.5) I_E W_t / R_s$.

- 8)** The total lateral earthquake design force, V_s , shall be distributed over the height of the *building* in accordance with the following formula:

$$F_x = V_s W_x h_x / \left(\sum_{i=1}^n W_i h_i \right)$$

where

F_x = force applied through the centre of mass at level x,

W_x, W_i = portion of W that is located at or is assigned to level x or i respectively, and

h_x, h_i = height, in m, above the base of level x and level i as per Article 4.1.8.2.

- 9)** Accidental torsional effects applied concurrently with F_x shall be considered by applying torsional moments about the vertical axis at each level for each of the following cases considered separately:

a) $+0.1D_{nx}F_x$, and

b) $-0.1D_{nx}F_x$.

- 10)** Deflections obtained from a linear analysis shall include the effects of torsion and be multiplied by R_s/I_E to get realistic values of expected deflections.

- 11)** The deflections referred to in Sentence (10) shall be used to calculate the largest interstorey deflection, which shall not exceed

a) $0.01h_s$ for *post-disaster buildings*,

b) $0.02h_s$ for High Importance Category *buildings*, and

c) $0.025h_s$ for all other *buildings*,

where h_s is the interstorey height as defined in Article 4.1.8.2.

- 12)** When earthquake forces are calculated using $R_s = 1.5$, the following elements in the SFRS shall have their design forces due to earthquake effects increased by 33%:

a) diaphragms and their chords, connections, struts and collectors,

- b) tie downs in wood or drywall shear walls,
- c) connections and anchor bolts in steel- and wood-braced frames,
- d) connections in precast concrete, and
- e) connections in steel moment frames.

13) Except as provided in Sentence (14), where cantilever parapet walls, other cantilever walls, exterior ornamentation and appendages, towers, chimneys or penthouses are connected to or form part of a *building*, they shall be designed, along with their connections, for a lateral force, V_{sp} , distributed according to the distribution of mass of the element and acting in the lateral direction that results in the most critical loading for design using the following equation:

$$V_{sp} = 0.1F_s I_E W_p$$

where W_p = weight of a portion of a structure as defined in Article 4.1.8.2.

14) The value of V_{sp} shall be doubled for unreinforced masonry elements.

15) Structures designed in accordance with this Article need not comply with the seismic requirements stated in the applicable design standard referenced in Section 4.3.

4.1.8.2. Notation

1) In this Subsection

- A_r = response amplification factor to account for type of attachment of mechanical/electrical equipment, as defined in Sentence 4.1.8.18.(1),
- A_x = amplification factor at level x to account for variation of response of mechanical/electrical equipment with elevation within the *building*, as defined in Sentence 4.1.8.18.(1),
- B_x = ratio at level x used to determine torsional sensitivity, as defined in Sentence 4.1.8.11.(10),
- B = maximum value of B_x , as defined in Sentence 4.1.8.11.(10),
- C_p = seismic coefficient for mechanical/electrical equipment, as defined in Sentence 4.1.8.18.(1),
- D_{nx} = plan dimension of the *building* at level x perpendicular to the direction of seismic loading being considered,
- e_x = distance measured perpendicular to the direction of earthquake loading between centre of mass and centre of rigidity at the level being considered (See Note A-4.1.8.2.(1).),
- F_a = site coefficient for application in Subsection 4.1.8., as defined in Sentence 4.1.8.4.(7),
- $F(\text{PGA})$ = site coefficient for PGA, as defined in Sentence 4.1.8.4.(5),
- $F(\text{PGV})$ = site coefficient for PGV, as defined in Sentence 4.1.8.4.(5),
- F_s = site coefficient as defined in Sentence 4.1.8.1.(2) for application in Article 4.1.8.1.,
- $F(T)$ = site coefficient for spectral acceleration, as defined in Sentence 4.1.8.4.(5),
- F_t = portion of V to be concentrated at the top of the structure, as defined in Sentence 4.1.8.11.(7),
- F_v = site coefficient for application in Subsection 4.1.8., as defined in Sentence 4.1.8.4.(7),
- F_x = lateral force applied to level x, as defined in Sentence 4.1.8.11.(7),
- h_i, h_n, h_x = the height above the base ($i = 0$) to level i, n, or x respectively, where the base of the structure is the level at which horizontal earthquake motions are considered to be imparted to the structure,
- h_s = interstorey height ($h_i - h_{i-1}$),
- I_E = earthquake importance factor of the structure, as described in Sentence 4.1.8.5.(1),
- J = numerical reduction coefficient for base overturning moment, as defined in Sentence 4.1.8.11.(6),
- J_x = numerical reduction coefficient for overturning moment at level x, as defined in Sentence 4.1.8.11.(8),
- Level i = any level in the *building*, $i = 1$ for first level above the base,
- Level n = level that is uppermost in the main portion of the structure,
- Level x = level that is under design consideration,
- M_v = factor to account for higher mode effect on base shear, as defined in Sentence 4.1.8.11.(6),
- M_x = overturning moment at level x, as defined in Sentence 4.1.8.11.(8),

- N = total number of *storeys* above exterior *grade* to level n ,
- \bar{N}_{60} = Average Standard Penetration Resistance for the top 30 m, corrected to a rod energy efficiency of 60% of the theoretical maximum,
- PGA = Peak Ground Acceleration expressed as a ratio to gravitational acceleration, as defined in Sentence 4.1.8.4.(1),
- PGA_{ref} = reference PGA for determining F(T), F(PGA) and F(PGV), as defined in Sentence 4.1.8.4.(4),
- PGV = Peak Ground Velocity, in m/s, as defined in Sentence 4.1.8.4.(1),
- PI = plasticity index for clays,
- R_d = ductility-related force modification factor reflecting the capability of a structure to dissipate energy through reversed cyclic inelastic behaviour, as given in Article 4.1.8.9.,
- R_o = overstrength-related force modification factor accounting for the dependable portion of reserve strength in a structure designed according to these provisions, as defined in Article 4.1.8.9.,
- R_s = combined overstrength and ductility-related modification factor, as defined in Sentence 4.1.8.1.(7), for application in Article 4.1.8.1.,
- S_p = horizontal force factor for part or portion of a *building* and its anchorage, as given in Sentence 4.1.8.18.(1),
- S(T) = design spectral response acceleration, expressed as a ratio to gravitational acceleration, for a period of T, as defined in Sentence 4.1.8.4.(9),
- $S_a(T)$ = 5% damped spectral response acceleration, expressed as a ratio to gravitational acceleration, for a period of T, as defined in Sentence 4.1.8.4.(1),
- SFRS = Seismic Force Resisting System(s) is that part of the structural system that has been considered in the design to provide the required resistance to the earthquake forces and effects defined in Subsection 4.1.8.,
- s_u = average undrained shear strength in the top 30 m of *soil*,
- T = period in seconds,
- T_a = fundamental lateral period of vibration of the *building* or structure, in s, in the direction under consideration, as defined in Sentence 4.1.8.11.(3),
- T_s = fundamental lateral period of vibration of the *building* or structure, in s, in the direction under consideration, as defined in Sentence 4.1.8.1.(7),
- T_x = floor torque at level x, as defined in Sentence 4.1.8.11.(11),
- TDD = Total Design Displacement of any point in a seismically isolated structure, within or above the isolation system, obtained by calculating the mean + ($I_E \times$ the standard deviation) of the peak horizontal displacements from all sets of ground motion histories analyzed, but not less than $\sqrt{I_E} \times$ the mean, where the peak horizontal displacement is based on the vector sum of the two orthogonal horizontal displacements considered for each time step,
- V = lateral earthquake design force at the base of the structure, as determined by Article 4.1.8.11.,
- V_d = lateral earthquake design force at the base of the structure, as determined by Article 4.1.8.12.,
- V_e = lateral earthquake elastic force at the base of the structure, as determined by Article 4.1.8.12.,
- V_{ed} = lateral earthquake design elastic force at the base of the structure, as determined by Article 4.1.8.12.,
- V_p = lateral force on a part of the structure, as determined by Article 4.1.8.18.,
- V_s = lateral earthquake design force at the base of the structure, as determined by Sentence 4.1.8.1.(7), for application in Article 4.1.8.1.,
- \bar{V}_{s30} = average shear wave velocity in the top 30 m of *soil* or *rock*,
- W = *dead load*, as defined in Article 4.1.4.1., except that the minimum *partition* load as defined in Sentence 4.1.4.1.(3) need not exceed 0.5 kPa, plus 25% of the design snow load specified in Subsection 4.1.6., plus 60% of the storage load for areas used for storage, except that *storage garages* need not be considered storage areas, and the full contents of any tanks (See Note A-4.1.8.2.(1).),

- W_i, W_x = portion of W that is located at or is assigned to level i or x respectively,
 W_p = weight of a part or portion of a structure, e.g., cladding, *partitions* and appendages,
 W_t = sum of W_i over the height of the *building*, for application in Sentence 4.1.8.1.(7),
 δ_{ave} = average displacement of the structure at level x , as defined in Sentence 4.1.8.11.(10), and
 δ_{max} = maximum displacement of the structure at level x , as defined in Sentence 4.1.8.11.(10).

4.1.8.3. General Requirements

- 1) Except as provided in Sentence (9), the *building* shall be designed to meet the requirements of this Subsection and of the design standards referenced in Section 4.3.
- 2) Structures shall be designed with a clearly defined load path, or paths, that will transfer the inertial forces generated in an earthquake to the supporting ground.
- 3) The structure shall have a clearly defined Seismic Force Resisting System(s) (SFRS), as defined in Article 4.1.8.2.
- 4) The SFRS shall be designed to resist 100% of the earthquake loads and their effects.
(See Note A-4.1.8.3.(4).)
- 5) All structural framing elements not considered to be part of the SFRS must be investigated and shown to behave elastically or to have sufficient non-linear capacity to support their gravity loads while undergoing earthquake-induced deformations calculated from the deflections determined in Article 4.1.8.13.
- 6) Stiff elements that are not considered part of the SFRS, such as concrete, masonry, brick or precast walls or panels, shall be
 - a) separated from all structural elements of the *building* such that no interaction takes place as the *building* undergoes deflections due to earthquake effects as calculated in this Subsection, or
 - b) made part of the SFRS and satisfy the requirements of this Subsection.
 (See Note A-4.1.8.3.(6).)
- 7) Stiffness imparted to the structure from elements not part of the SFRS, other than those described in Sentence (6), shall not be used to resist earthquake deflections but shall be accounted for
 - a) in calculating the period of the structure for determining forces if the added stiffness decreases the fundamental lateral period by more than 15%,
 - b) in determining the irregularity of the structure, except the additional stiffness shall not be used to make an irregular SFRS regular or to reduce the effects of torsion (See Note A-4.1.8.3.(7)(b) and (c).), and
 - c) in designing the SFRS if inclusion of the elements not part of the SFRS in the analysis has an adverse effect on the SFRS (See Note A-4.1.8.3.(7)(b) and (c).).
- 8) Structural modelling shall be representative of the magnitude and spatial distribution of the mass of the *building* and of the stiffness of all elements of the SFRS, including stiff elements that are not separated in accordance with Sentence 4.1.8.3.(6), and shall account for
 - a) the effect of cracked sections in reinforced concrete and reinforced masonry elements,
 - b) the effect of the finite size of members and joints,
 - c) sway effects arising from the interaction of gravity loads with the displaced configuration of the structure, and
 - d) other effects that influence the lateral stiffness of the *building*.
 (See Note A-4.1.8.3.(8).)
- 9) Notwithstanding the requirement stated in Sentence 4.3.1.1.(1), Update 1 to CSA O86-14 is not permitted to be used in the application of Subsection 4.1.8.

Rev.
12715

4.1.8.4. Site Properties

- 1) The peak ground acceleration (PGA), peak ground velocity (PGV), and the 5% damped spectral response acceleration values, $S_a(T)$, for the reference ground conditions (Site Class C in Table 4.1.8.4.-A) for periods T of 0.2 s, 0.5 s, 1.0 s, 2.0 s, 5.0 s and 10.0 s shall be determined in accordance with Subsection 1.1.3. and are based on a 2% probability of exceedance in 50 years.

Rev.
12715

Table 4.1.8.4.-A
Site Classification for Seismic Site Response
 Forming Part of Sentences 4.1.8.4.(1) to (3)

Site Class	Ground Profile Name	Average Properties in Top 30 m, as per Note A-4.1.8.4.(3) and Table 4.1.8.4.-A		
		Average Shear Wave Velocity, \bar{V}_{s30} , m/s	Average Standard Penetration Resistance, \bar{N}_{60}	Soil Undrained Shear Strength, s_u
A	Hard <i>rock</i> ⁽¹⁾⁽²⁾	$\bar{V}_{s30} > 1500$	n/a	n/a
B	<i>Rock</i> ⁽¹⁾	$760 < \bar{V}_{s30} \leq 1500$	n/a	n/a
C	Very dense <i>soil</i> and soft <i>rock</i>	$360 < \bar{V}_{s30} < 760$	$\bar{N}_{60} > 50$	$s_u > 100$ kPa
D	Stiff <i>soil</i>	$180 < \bar{V}_{s30} < 360$	$15 \leq \bar{N}_{60} \leq 50$	$50 \text{ kPa} < s_u \leq 100$ kPa
E	Soft <i>soil</i>	$\bar{V}_{s30} < 180$	$\bar{N}_{60} < 15$	$s_u < 50$ kPa
		Any profile with more than 3 m of <i>soil</i> with the following characteristics: <ul style="list-style-type: none"> • plasticity index: $PI > 20$ • moisture content: $w \geq 40\%$, and • undrained shear strength: $s_u < 25$ kPa 		
F	Other <i>soils</i> ⁽³⁾	Site-specific evaluation required		

Notes to Table 4.1.8.4.-A:

- (1) Site Classes A and B, hard *rock* and *rock*, are not to be used if there is more than 3 m of softer materials between the *rock* and the underside of footing or mat *foundations*. The appropriate Site Class for such cases is determined on the basis of the average properties of the total thickness of the softer materials (See Note A-4.1.8.4.(3) and Table 4.1.8.4.-A).
- (2) Where \bar{V}_{s30} has been measured in-situ, the F(T) values for Site Class A derived from Tables 4.1.8.4.-B to 4.1.8.4.-G are permitted to be multiplied by the factor $0.04 + (1500/\bar{V}_{s30})^{1/2}$.
- (3) Other *soils* include:
 - a) liquefiable *soils*, quick and highly sensitive clays, collapsible weakly cemented *soils*, and other *soils* susceptible to failure or collapse under seismic loading,
 - b) peat and/or highly organic clays greater than 3 m in thickness,
 - c) highly plastic clays ($PI > 75$) more than 8 m thick, and
 - d) soft to medium stiff clays more than 30 m thick.

2) Site classifications for ground shall conform to Table 4.1.8.4.-A and shall be determined using \bar{V}_{s30} , or where \bar{V}_{s30} is not known, using Sentence (3).

3) If average shear wave velocity, \bar{V}_{s30} , is not known, Site Class shall be determined from energy-corrected Average Standard Penetration Resistance, \bar{N}_{60} , or from *soil* average undrained shear strength, s_u , as noted in Table 4.1.8.4.-A, \bar{N}_{60} and s_u being calculated based on rational analysis. (See Note A-4.1.8.4.(3) and Table 4.1.8.4.-A.)

4) For the purpose of determining the values of F(T) to be used in the calculation of design spectral acceleration, S(T), in Sentence (9), and the values of F(PGA) and F(PGV), the value of PGA_{ref} to be used with Tables 4.1.8.4.-B to 4.1.8.4.-I shall be taken as

- a) 0.8 PGA, where the ratio $S_a(0.2)/PGA < 2.0$, and
- b) PGA, otherwise.

5) The values of the site coefficient for design spectral acceleration at period T, F(T), and of similar coefficients F(PGA) and F(PGV) shall conform to Tables 4.1.8.4.-B to 4.1.8.4.-I using linear interpolation for intermediate values of PGA_{ref} .

6) Site-specific evaluation is required to determine F(T), F(PGA) and F(PGV) for Site Class F. (See Note A-4.1.8.4.(3) and Table 4.1.8.4.-A.)

7) For all applications in Subsection 4.1.8., $F_a = F(0.2)$ and $F_v = F(1.0)$.

8) For structures with a fundamental period of vibration equal to or less than 0.5 s that are built on liquefiable *soils*, Site Class and the corresponding values of F(T) may be determined as described in Tables 4.1.8.4.-A, 4.1.8.4.-B, and 4.1.8.4.-C by assuming that the *soils* are not liquefiable. (See Note A-4.1.8.4.(3) and Table 4.1.8.4.-A.)

9) The design spectral acceleration values of $S(T)$ shall be determined as follows, using linear interpolation for intermediate values of T :

$$\begin{aligned} S(T) &= F(0.2)S_a(0.2) \text{ or } F(0.5)S_a(0.5), \text{ whichever is larger, for } T \leq 0.2 \text{ s} \\ &= F(0.5)S_a(0.5) \text{ for } T = 0.5 \text{ s} \\ &= F(1.0)S_a(1.0) \text{ for } T = 1.0 \text{ s} \\ &= F(2.0)S_a(2.0) \text{ for } T = 2.0 \text{ s} \\ &= F(5.0)S_a(5.0) \text{ for } T = 5.0 \text{ s} \\ &= F(10.0)S_a(10.0) \text{ for } T \geq 10.0 \text{ s} \end{aligned}$$

Table 4.1.8.4.-B
Values of F(0.2) as a Function of Site Class and PGA_{ref}
 Forming Part of Sentences 4.1.8.4.(4) and (5)

Site Class	Values of F(0.2)				
	$PGA_{ref} \leq 0.1$	$PGA_{ref} = 0.2$	$PGA_{ref} = 0.3$	$PGA_{ref} = 0.4$	$PGA_{ref} \geq 0.5$
A	0.69	0.69	0.69	0.69	0.69
B	0.77	0.77	0.77	0.77	0.77
C	1.00	1.00	1.00	1.00	1.00
D	1.24	1.09	1.00	0.94	0.90
E	1.64	1.24	1.05	0.93	0.85
F	(1)	(1)	(1)	(1)	(1)

Notes to Table 4.1.8.4.-B:

(1) See Sentence 4.1.8.4.(6).

Table 4.1.8.4.-C
Values of F(0.5) as a Function of Site Class and PGA_{ref}
 Forming Part of Sentences 4.1.8.4.(4) and (5)

Site Class	Values of F(0.5)				
	$PGA_{ref} \leq 0.1$	$PGA_{ref} = 0.2$	$PGA_{ref} = 0.3$	$PGA_{ref} = 0.4$	$PGA_{ref} \geq 0.5$
A	0.57	0.57	0.57	0.57	0.57
B	0.65	0.65	0.65	0.65	0.65
C	1.00	1.00	1.00	1.00	1.00
D	1.47	1.30	1.20	1.14	1.10
E	2.47	1.80	1.48	1.30	1.17
F	(1)	(1)	(1)	(1)	(1)

Notes to Table 4.1.8.4.-C:

(1) See Sentence 4.1.8.4.(6).

Table 4.1.8.4.-D
Values of F(1.0) as a Function of Site Class and PGA_{ref}
 Forming Part of Sentences 4.1.8.4.(4) and (5)

Site Class	Values of F(1.0)				
	$PGA_{ref} \leq 0.1$	$PGA_{ref} = 0.2$	$PGA_{ref} = 0.3$	$PGA_{ref} = 0.4$	$PGA_{ref} \geq 0.5$
A	0.57	0.57	0.57	0.57	0.57
B	0.63	0.63	0.63	0.63	0.63
C	1.00	1.00	1.00	1.00	1.00
D	1.55	1.39	1.31	1.25	1.21
E	2.81	2.08	1.74	1.53	1.39
F	(1)	(1)	(1)	(1)	(1)

Notes to Table 4.1.8.4.-D:

(1) See Sentence 4.1.8.4.(6).

Table 4.1.8.4.-E
Values of F(2.0) as a Function of Site Class and PGA_{ref}
 Forming Part of Sentences 4.1.8.4.(4) and (5)

Site Class	Values of F(2.0)				
	$PGA_{ref} \leq 0.1$	$PGA_{ref} = 0.2$	$PGA_{ref} = 0.3$	$PGA_{ref} = 0.4$	$PGA_{ref} \geq 0.5$
A	0.58	0.58	0.58	0.58	0.58
B	0.63	0.63	0.63	0.63	0.63
C	1.00	1.00	1.00	1.00	1.00
D	1.57	1.44	1.36	1.31	1.27
E	2.90	2.24	1.92	1.72	1.58
F	(1)	(1)	(1)	(1)	(1)

Notes to Table 4.1.8.4.-E:

(1) See Sentence 4.1.8.4.(6).

Table 4.1.8.4.-F
Values of F(5.0) as a Function of Site Class and PGA_{ref}
 Forming Part of Sentences 4.1.8.4.(4) and (5)

Site Class	Values of F(5.0)				
	$PGA_{ref} \leq 0.1$	$PGA_{ref} = 0.2$	$PGA_{ref} = 0.3$	$PGA_{ref} = 0.4$	$PGA_{ref} \geq 0.5$
A	0.61	0.61	0.61	0.61	0.61
B	0.64	0.64	0.64	0.64	0.64
C	1.00	1.00	1.00	1.00	1.00
D	1.58	1.48	1.41	1.37	1.34
E	2.93	2.40	2.14	1.96	1.84
F	(1)	(1)	(1)	(1)	(1)

Notes to Table 4.1.8.4.-F:

(1) See Sentence 4.1.8.4.(6).

Table 4.1.8.4.-G
Values of F(10.0) as a Function of Site Class and PGA_{ref}
 Forming Part of Sentences 4.1.8.4.(4) and (5)

Site Class	Values of F(10.0)				
	$PGA_{ref} \leq 0.1$	$PGA_{ref} = 0.2$	$PGA_{ref} = 0.3$	$PGA_{ref} = 0.4$	$PGA_{ref} \geq 0.5$
A	0.67	0.67	0.67	0.67	0.67
B	0.69	0.69	0.69	0.69	0.69
C	1.00	1.00	1.00	1.00	1.00
D	1.49	1.41	1.37	1.34	1.31
E	2.52	2.18	2.00	1.88	1.79
F	(1)	(1)	(1)	(1)	(1)

Notes to Table 4.1.8.4.-G:

(1) See Sentence 4.1.8.4.(6).

Table 4.1.8.4.-H
Values of F(PGA) as a Function of Site Class and PGA_{ref}
 Forming Part of Sentences 4.1.8.4.(4) and (5)

Site Class	Values of F(PGA)				
	$PGA_{ref} \leq 0.1$	$PGA_{ref} = 0.2$	$PGA_{ref} = 0.3$	$PGA_{ref} = 0.4$	$PGA_{ref} \geq 0.5$
A	0.90	0.90	0.90	0.90	0.90
B	0.87	0.87	0.87	0.87	0.87
C	1.00	1.00	1.00	1.00	1.00
D	1.29	1.10	0.99	0.93	0.88
E	1.81	1.23	0.98	0.83	0.74
F	(1)	(1)	(1)	(1)	(1)

Notes to Table 4.1.8.4.-H:

(1) See Sentence 4.1.8.4.(6).

Table 4.1.8.4.-I
Values of F(PGV) as a Function of Site Class and PGA_{ref}
 Forming Part of Sentences 4.1.8.4.(4) and (5)

Site Class	Values of F(PGV)				
	$PGA_{ref} \leq 0.1$	$PGA_{ref} = 0.2$	$PGA_{ref} = 0.3$	$PGA_{ref} = 0.4$	$PGA_{ref} \geq 0.5$
A	0.62	0.62	0.62	0.62	0.62
B	0.67	0.67	0.67	0.67	0.67
C	1.00	1.00	1.00	1.00	1.00
D	1.47	1.30	1.20	1.14	1.10
E	2.47	1.80	1.48	1.30	1.17
F	(1)	(1)	(1)	(1)	(1)

Notes to Table 4.1.8.4.-I:

(1) See Sentence 4.1.8.4.(6).

4.1.8.5. Importance Factor

- The earthquake importance factor, I_E , shall be determined according to Table 4.1.8.5.

Table 4.1.8.5.
Importance Factor for Earthquake Loads and Effects, I_E
 Forming Part of Sentence 4.1.8.5.(1)

Importance Category	Importance Factor, I_E	
	ULS	SLS ⁽¹⁾
Low	0.8	(2)
Normal	1.0	
High	1.3	
Post-disaster	1.5	

Notes to Table 4.1.8.5.:

(1) See Article 4.1.8.13.

(2) See Note A-Table 4.1.8.5.

4.1.8.6. Structural Configuration

- 1) Structures having any of the features listed in Table 4.1.8.6. shall be designated irregular.
- 2) Structures not classified as irregular according to Sentence 4.1.8.6.(1) may be considered regular.
- 3) Except as required by Article 4.1.8.10., in cases where $I_E F_a S_a(0.2)$ is equal to or greater than 0.35, structures designated as irregular must satisfy the provisions referenced in Table 4.1.8.6.

Table 4.1.8.6.
Structural Irregularities⁽¹⁾
Forming Part of Sentence 4.1.8.6.(1)

Type	Irregularity Type and Definition	Notes
1	Vertical Stiffness Irregularity Vertical stiffness irregularity shall be considered to exist when the lateral stiffness of the SFRS in a <i>storey</i> is less than 70% of the stiffness of any adjacent <i>storey</i> , or less than 80% of the average stiffness of the three <i>storeys</i> above or below.	(2)(3)(4)
2	Weight (mass) Irregularity Weight irregularity shall be considered to exist where the weight, W_i , of any <i>storey</i> is more than 150% of the weight of an adjacent <i>storey</i> . A roof that is lighter than the floor below need not be considered.	(2)
3	Vertical Geometric Irregularity Vertical geometric irregularity shall be considered to exist where the horizontal dimension of the SFRS in any <i>storey</i> is more than 130% of that in an adjacent <i>storey</i> .	(2)(3)(4)(5)
4	In-Plane Discontinuity in Vertical Lateral-Force-Resisting Element Except for braced frames and moment-resisting frames, an in-plane discontinuity shall be considered to exist where there is an offset of a lateral-force-resisting element of the SFRS or a reduction in lateral stiffness of the resisting element in the <i>storey</i> below.	(2)(3)(4)(5)
5	Out-of-Plane Offsets Discontinuities in a lateral force path, such as out-of-plane offsets of the vertical elements of the SFRS.	(2)(3)(4)(5)
6	Discontinuity in Capacity – Weak Storey A weak <i>storey</i> is one in which the <i>storey</i> shear strength is less than that in the <i>storey</i> above. The <i>storey</i> shear strength is the total strength of all seismic-resisting elements of the SFRS sharing the <i>storey</i> shear for the direction under consideration.	(2)(3)
7	Torsional Sensitivity (to be considered when diaphragms are not flexible) Torsional sensitivity shall be considered to exist when the ratio B calculated according to Sentence 4.1.8.11.(10) exceeds 1.7.	(2)(3)(4)(6)
8	Non-orthogonal Systems A non-orthogonal system irregularity shall be considered to exist when the SFRS is not oriented along a set of orthogonal axes.	(2)(4)(7)
9	Gravity-Induced Lateral Demand Irregularity Gravity-induced lateral demand irregularity on the SFRS shall be considered to exist where the ratio, α , calculated in accordance with Sentence 4.1.8.10.(5), exceeds 0.1 for an SFRS with self-centering characteristics and 0.03 for other systems.	(2)(3)(4)(7)

Notes to Table 4.1.8.6.:

- (1) One-*storey* penthouses with a weight of less than 10% of the level below need not be considered in the application of this Table.
- (2) See Article 4.1.8.7.
- (3) See Article 4.1.8.10.
- (4) See Note A-Table 4.1.8.6.
- (5) See Article 4.1.8.15.
- (6) See Sentences 4.1.8.11.(10), (11) and 4.1.8.12.(4).
- (7) See Article 4.1.8.8.

4.1.8.7. Methods of Analysis

1) Analysis for design earthquake actions shall be carried out in accordance with the Dynamic Analysis Procedure described in Article 4.1.8.12. (See Note A-4.1.8.7.(1).), except that the Equivalent Static Force Procedure described in Article 4.1.8.11. may be used for structures that meet any of the following criteria:

- a) in cases where $I_E F_a S_a(0.2)$ is less than 0.35,
- b) regular structures that are less than 60 m in height and have a fundamental lateral period, T_a , less than 2 s in each of two orthogonal directions as defined in Article 4.1.8.8., or
- c) structures with structural irregularity, of Type 1, 2, 3, 4, 5, 6 or 8 as defined in Table 4.1.8.6., that are less than 20 m in height and have a fundamental lateral period, T_a , less than 0.5 s in each of two orthogonal directions as defined in Article 4.1.8.8.

4.1.8.8. Direction of Loading

1) Earthquake forces shall be assumed to act in any horizontal direction, except that the following shall be considered to provide adequate design force levels in the structure:

- a) where components of the SFRS are oriented along a set of orthogonal axes, independent analyses about each of the principal axes of the structure shall be performed,
- b) where the components of the SFRS are not oriented along a set of orthogonal axes and $I_E F_a S_a(0.2)$ is less than 0.35, independent analyses about any two orthogonal axes is permitted, or
- c) where the components of the SFRS are not oriented along a set of orthogonal axes and $I_E F_a S_a(0.2)$ is equal to or greater than 0.35, analysis of the structure independently in any two orthogonal directions for 100% of the prescribed earthquake loads applied in one direction plus 30% of the prescribed earthquake loads in the perpendicular direction, with the combination requiring the greater element strength being used in the design.

4.1.8.9. SFRS Force Reduction Factors, System Overstrength Factors, and General Restrictions

1) Except as provided in Sentence 4.1.8.20.(7), the values of R_d and R_o and the corresponding system restrictions shall conform to Table 4.1.8.9. and the requirements of this Subsection.

2) When a particular value of R_d is required by this Article, the corresponding R_o shall be used.

3) For combinations of different types of SFRS acting in the same direction in the same *storey*, $R_d R_o$ shall be taken as the lowest value of $R_d R_o$ corresponding to these systems.

4) For vertical variations of $R_d R_o$, excluding rooftop structures not exceeding two *storeys* in height whose weight is less than the greater of 10% of W and 30% of W_i of the level below, the value of $R_d R_o$ used in the design of any *storey* shall be less than or equal to the lowest value of $R_d R_o$ used in the given direction for the *storeys* above, and the requirements of Sentence 4.1.8.15.(6) must be satisfied. (See Note A-4.1.8.9.(4).)

5) If it can be demonstrated through testing, research and analysis that the seismic performance of a structural system is at least equivalent to one of the types of SFRS mentioned in Table 4.1.8.9., then such a structural system will qualify for values of R_d and R_o corresponding to the equivalent type in that Table. (See Note A-4.1.8.9.(5).)

Table 4.1.8.9.
SFRS Ductility-Related Force Modification Factors, R_d , Overstrength-Related Force
Modification Factors, R_o , and General Restrictions⁽¹⁾
 Forming Part of Sentence 4.1.8.9.(1)

Type of SFRS	R_d	R_o	Restrictions ⁽²⁾				
			Cases Where $I_E F_a S_a(0.2)$				Cases Where $I_E F_v S_a(1.0)$
			< 0.2	≥ 0.2 to < 0.35	≥ 0.35 to ≤ 0.75	> 0.75	> 0.3
Steel Structures Designed and Detailed According to CSA S16 ⁽³⁾⁽⁴⁾							
Ductile moment-resisting frames	5.0	1.5	NL	NL	NL	NL	NL
Moderately ductile moment-resisting frames	3.5	1.5	NL	NL	NL	NL	NL
Limited ductility moment-resisting frames	2.0	1.3	NL	NL	60	30	30
Moderately ductile concentrically braced frames							
Tension-compression braces	3.0	1.3	NL	NL	40	40	40
Tension only braces	3.0	1.3	NL	NL	20	20	20
Limited ductility concentrically braced frames							
Tension-compression braces	2.0	1.3	NL	NL	60	60	60
Tension only braces	2.0	1.3	NL	NL	40	40	40
Ductile buckling-restrained braced frames	4.0	1.2	NL	NL	40	40	40
Ductile eccentrically braced frames	4.0	1.5	NL	NL	NL	NL	NL
Ductile plate walls	5.0	1.6	NL	NL	NL	NL	NL
Limited ductility plate walls	2.0	1.5	NL	NL	60	60	60
Conventional <i>construction</i> of moment-resisting frames, braced frames or plate walls							
<i>Assembly occupancies</i>	1.5	1.3	NL	NL	15	15	15
<i>Other occupancies</i>	1.5	1.3	NL	NL	60	40	40
Other steel SFRS(s) not defined above	1.0	1.0	15	15	NP	NP	NP
Concrete Structures Designed and Detailed According to CSA A23.3							
Ductile moment-resisting frames	4.0	1.7	NL	NL	NL	NL	NL
Moderately ductile moment-resisting frames	2.5	1.4	NL	NL	60	40	40
Ductile coupled walls	4.0	1.7	NL	NL	NL	NL	NL
Moderately ductile coupled walls	2.5	1.4	NL	NL	NL	60	60
Ductile partially coupled walls	3.5	1.7	NL	NL	NL	NL	NL
Moderately ductile partially coupled walls	2.0	1.4	NL	NL	NL	60	60
Ductile shear walls	3.5	1.6	NL	NL	NL	NL	NL
Moderately ductile shear walls	2.0	1.4	NL	NL	NL	60	60
Conventional <i>construction</i>							
Moment-resisting frames	1.5	1.3	NL	NL	20	15	10 ⁽⁵⁾
Shear walls	1.5	1.3	NL	NL	40	30	30
Two-way slabs without beams	1.3	1.3	20	15	NP	NP	NP
Tilt-up <i>construction</i>							
Moderately ductile walls and frames	2.0	1.3	30	25	25	25	25
Limited ductility walls and frames	1.5	1.3	30	25	20	20	20 ⁽⁶⁾
Conventional walls and frames	1.3	1.3	25	20	NP	NP	NP
Other concrete SFRS(s) not listed above	1.0	1.0	15	15	NP	NP	NP

Table 4.1.8.9. (continued)
SFRS Ductility-Related Force Modification Factors, R_d , Overstrength-Related Force Modification Factors, R_o , and General Restrictions⁽¹⁾
 Forming Part of Sentence 4.1.8.9.(1)

Type of SFRS	R_d	R_o	Restrictions ⁽²⁾				
			Cases Where $I_E F_a S_a(0.2)$				Cases Where $I_E F_v S_a(1.0)$
			< 0.2	≥ 0.2 to < 0.35	≥ 0.35 to ≤ 0.75	> 0.75	> 0.3
Timber Structures Designed and Detailed According to CSA O86							
Shear walls							
Nailed shear walls: wood-based panel	3.0	1.7	NL	NL	30	20	20
Shear walls: wood-based and gypsum panels in combination	2.0	1.7	NL	NL	20	20	20
Braced or moment-resisting frames with ductile connections							
Moderately ductile	2.0	1.5	NL	NL	20	20	20
Limited ductility	1.5	1.5	NL	NL	15	15	15
Other wood- or gypsum-based SFRS(s) not listed above	1.0	1.0	15	15	NP	NP	NP
Moderately ductile cross-laminated timber shear walls: platform-type construction	2.0	1.5	30	30	30	20	20
Limited ductility cross-laminated timber shear walls: platform-type construction	1.0	1.3	30	30	30	20	20
Masonry Structures Designed and Detailed According to CSA S304							
Ductile shear walls	3.0	1.5	NL	NL	60	40	40
Moderately ductile shear walls	2.0	1.5	NL	NL	60	40	40
Conventional construction							
Shear walls	1.5	1.5	NL	60	30	15	15
Moment-resisting frames	1.5	1.5	NL	30	NP	NP	NP
Unreinforced masonry	1.0	1.0	30	15	NP	NP	NP
Other masonry SFRS(s) not listed above	1.0	1.0	15	NP	NP	NP	NP
Cold-Formed Steel Structures Designed and Detailed According to CSA S136							
Shear walls							
Screw-connected shear walls – wood-based panels	2.5	1.7	20	20	20	20	20
Screw-connected shear walls – wood-based and gypsum panels in combination	1.5	1.7	20	20	20	20	20
Diagonal strap concentrically braced walls							
Limited ductility	1.9	1.3	20	20	20	20	20
Conventional construction	1.2	1.3	15	15	NP	NP	NP
Other cold-formed SFRS(s) not defined above	1.0	1.0	15	15	NP	NP	NP

Rev. 12715

Notes to Table 4.1.8.9.:

(1) See Article 4.1.8.10.

(2) NP = system is not permitted.

NL = system is permitted and not limited in height as an SFRS.

Numbers in this Table are maximum height limits above *grade*, in m.

Height may be limited in other Parts of the By-law.

The most stringent requirement governs.

- (3) Higher design force levels are prescribed in CSA S16 for some heights of *buildings*.
- (4) See Note A-Table 4.1.8.9.
- (5) Frames limited to a maximum of 2 *storeys*.
- (6) Frames limited to a maximum of 3 *storeys*.

4.1.8.10. Additional System Restrictions

- 1)** Except as required by Clause (2)(b), structures with a Type 6 irregularity, Discontinuity in Capacity – Weak *Storey*, as described in Table 4.1.8.6., are not permitted unless $I_E F_a S_a(0.2)$ is less than 0.2 and the forces used for design of the SFRS are multiplied by $R_d R_o$.
- 2)** *Post-disaster buildings* shall
- not have any irregularities conforming to Types 1, 3, 4, 5, 7 and 9 as described in Table 4.1.8.6., in cases where $I_E F_a S_a(0.2)$ is equal to or greater than 0.35,
 - not have a Type 6 irregularity as described in Table 4.1.8.6.,
 - have an SFRS with an R_d of 2.0 or greater, and
 - have no *storey* with a lateral stiffness that is less than that of the *storey* above it.
- 3)** For *buildings* having fundamental lateral periods, T_a , of 1.0 s or greater, and where $I_E F_v S_a(1.0)$ is greater than 0.25, shear walls that are other than wood-based and form part of the SFRS shall be continuous from their top to the *foundation* and shall not have irregularities of Type 4 or 5 as described in Table 4.1.8.6.
- 4)** For *buildings* constructed with more than 4 *storeys* of continuous wood construction and where $I_E F_a S_a(0.2)$ is equal to or greater than 0.35, timber SFRS consisting of shear walls with wood-based panels or of braced or moment-resisting frames as defined in Table 4.1.8.9. within the continuous wood construction shall not have Type 4 or Type 5 irregularities as described in Table 4.1.8.6. (See Note A-4.1.8.10.(4) and (5)).
- 5)** For *buildings* constructed with more than 4 *storeys* of continuous wood construction and where $I E F_a S_a(0.2)$ is equal to or greater than 0.35, timber SFRS consisting of moderately ductile cross-laminated timber shear walls, platform-type construction, or limited ductility cross-laminated timber shear walls, platform-type construction, as defined in Table 4.1.8.9. within the continuous wood construction shall not have Type 4, 5, 6, 8, 9 or 10 irregularities as described in Table 4.1.8.6. (See Note A-4.1.8.10.(4) and (5)).
- 6)** The ratio, α , for a Type 9 irregularity as described in Table 4.1.8.6. shall be determined independently for each orthogonal direction using the following equation:

$$\alpha = Q_G / Q_y$$

where

- Q_G = gravity-induced lateral demand on the SFRS at the critical level of the yielding system, and
- Q_y = the resistance of the yielding mechanism required to resist the minimum earthquake loads, which need not be taken as less than R_o multiplied by the minimum lateral earthquake force as determined in Article 4.1.8.11. or 4.1.8.12., as appropriate.

(See Note A-4.1.8.10.(5).)

7) For *buildings* with a Type 9 irregularity as described in Table 4.1.8.6. and where $I_E F_a S_a(0.2)$ is equal to or greater than 0.5, deflections determined in accordance with Article 4.1.8.13. shall be multiplied by 1.2.

8) Structures where the value of α , as determined in accordance with Sentence (5), exceeds twice the limits specified in Table 4.1.8.6. for a Type 9 irregularity, and where $I_E F_a S_a(0.2)$ is equal to or greater than 0.5 are not permitted unless determined to be acceptable based on non-linear dynamic analysis studies. (See Note A-4.1.8.10.(7).)

4.1.8.11. Equivalent Static Force Procedure for Structures Satisfying the Conditions of Article 4.1.8.7.

- 1)** The static loading due to earthquake motion shall be determined according to the procedures given in this Article.
- 2)** Except as provided in Sentence (12), the minimum lateral earthquake force, V , shall be calculated using the following formula:

Rev.
12683

Rev.
12683

$$V = S (T_a) M_v I_E W / (R_d R_o)$$

except

- a) for walls, coupled walls and wall-frame systems, V shall not be less than

$$S (4.0) M_v I_E W / (R_d R_o)$$

- b) for moment-resisting frames, braced frames, and other systems, V shall not be less than

$$S (2.0) M_v I_E W / (R_d R_o)$$

- c) for *buildings* located on a site other than Class F and having an SFRS with an R_d equal to or greater than 1.5, V need not be greater than the larger of

$$\frac{2}{3} S (0.2) I_E W / (R_d R_o) \text{ and}$$

$$S (0.5) I_E W / (R_d R_o)$$

3) Except as provided in Sentence (4), the fundamental lateral period, T_a , in the direction under consideration in Sentence (2), shall be determined as:

- a) for moment-resisting frames that resist 100% of the required lateral forces and where the frame is not enclosed by or adjoined by more rigid elements that would tend to prevent the frame from resisting lateral forces, and where h_n is in metres:
- i) $0.085 (h_n)^{3/4}$ for steel moment frames,
 - ii) $0.075 (h_n)^{3/4}$ for concrete moment frames, or
 - iii) 0.1 N for other moment frames,
- b) $0.025 h_n$ for braced frames where h_n is in metres,
- c) $0.05 (h_n)^{3/4}$ for shear wall and other structures where h_n is in metres, or
- d) other established methods of mechanics using a structural model that complies with the requirements of Sentence 4.1.8.3.(8), except that
- i) for moment-resisting frames, T_a shall not be taken greater than 1.5 times that determined in Clause (a),
 - ii) for braced frames, T_a shall not be taken greater than 2.0 times that determined in Clause (b),
 - iii) for shear wall structures, T_a shall not be taken greater than 2.0 times that determined in Clause (c),
 - iv) for other structures, T_a shall not be taken greater than that determined in Clause (c), and
 - v) for the purpose of calculating the deflections, the period without the upper limit specified in Subclauses (d)(i) to (d)(iv) may be used, except that, for walls, coupled walls and wall-frame systems, T_a shall not exceed 4.0 s, and for moment-resisting frames, braced frames, and other systems, T_a shall not exceed 2.0 s.

(See Note A-4.1.8.11.(3).)

4) For single-storey *buildings* with steel deck or wood roof diaphragms, the fundamental lateral period, T_a , in the direction under consideration is permitted to be taken as

- a) $0.05 (h_n)^{3/4} + 0.004 L$ for shear walls,
- b) $0.035 h_n + 0.004 L$ for steel moment frames and steel braced frames, or
- c) the value obtained from methods of mechanics using a structural model that complies with the requirements of Sentence 4.1.8.3.(8), except that T_a shall not be greater than 1.5 times the value determined in Clause (a) or (b), as applicable,

where L is the shortest length of the diaphragm, in m, between adjacent vertical elements of the SFRS in the direction perpendicular to the direction under consideration.

5) The weight, W, of the *building* shall be calculated using the following formula:

$$W = \sum_{i=1}^n W_i$$

6) The higher mode factor, M_v , and its associated base overturning moment reduction factor, J, shall conform to Table 4.1.8.11.

7) The total lateral seismic force, V, shall be distributed such that a portion, F_p , shall be assumed to be

concentrated at the top of the *building*, where F_t is equal to $0.07 T_a V$ but need not exceed $0.25 V$ and may be considered as zero where the fundamental lateral period, T_a , does not exceed 0.7 s; the remainder, $V - F_t$, shall be distributed along the height of the *building*, including the top level, in accordance with the following formula:

$$F_x = (V - F_t) W_x h_x / \left(\sum_{i=1}^n W_i h_i \right)$$

Table 4.1.8.11.
Higher Mode Factor, M_v , and Base Overturning Reduction Factor, $J^{(1)(2)(3)(4)}$
 Forming Part of Sentence 4.1.8.11.(6)

S(0.2)/S(5.0)	M_v for $T_a \leq 0.5$	M_v for $T_a = 1.0$	M_v for $T_a = 2.0$	M_v for $T_a \geq 5.0$	J for $T_a \leq 0.5$	J for $T_a = 1.0$	J for $T_a = 2.0$	J for $T_a \geq 5.0$
Moment-Resisting Frames								
5	1	1	1	(5)	1	0.97	0.92	(5)
20	1	1	1	(5)	1	0.93	0.85	(5)
40	1	1	1	(5)	1	0.87	0.78	(5)
65	1	1	1.03	(5)	1	0.80	0.70	(5)
Coupled Walls⁽⁶⁾								
5	1	1	1	1 ⁽⁷⁾	1	0.97	0.92	0.80 ⁽⁸⁾
20	1	1	1	1.08 ⁽⁷⁾	1	0.93	0.85	0.65 ⁽⁸⁾
40	1	1	1	1.30 ⁽⁷⁾	1	0.87	0.78	0.53 ⁽⁸⁾
65	1	1	1.03	1.49 ⁽⁷⁾	1	0.80	0.70	0.46 ⁽⁸⁾
Braced Frames								
5	1	1	1	(5)	1	0.95	0.89	(5)
20	1	1	1	(5)	1	0.85	0.78	(5)
40	1	1	1	(5)	1	0.79	0.70	(5)
65	1	1.04	1.07	(5)	1	0.71	0.66	(5)
Walls, Wall Frame Systems								
5	1	1	1	1.25 ⁽⁷⁾	1	0.97	0.85	0.55 ⁽⁸⁾
20	1	1	1.18	2.30 ⁽⁷⁾	1	0.80	0.60	0.35 ⁽⁸⁾
40	1	1.19	1.75	3.70 ⁽⁷⁾	1	0.63	0.46	0.28 ⁽⁸⁾
65	1	1.55	2.25	4.65 ⁽⁷⁾	1	0.51	0.39	0.23 ⁽⁸⁾
Other Systems								
5	1	1	1	(5)	1	0.97	0.85	(5)
20	1	1	1.18	(5)	1	0.80	0.60	(5)
40	1	1.19	1.75	(5)	1	0.63	0.46	(5)
65	1	1.55	2.25	(5)	1	0.51	0.39	(5)

Notes to Table 4.1.8.11.:

- (1) For intermediate values of the spectral ratio S(0.2)/S(5.0), M_v and J shall be obtained by linear interpolation.
- (2) For intermediate values of the fundamental lateral period, T_a , $S(T_a)M_v$ shall be obtained by linear interpolation using the values of M_v obtained in accordance with Note (1).
- (3) For intermediate values of the fundamental lateral period, T_a , J shall be obtained by linear interpolation using the values of J obtained in accordance with Note (1).
- (4) For a combination of different seismic force resisting systems (SFRS) not given in Table 4.1.8.11. that are in the same direction under consideration, use the highest M_v factor of all the SFRS and the corresponding value of J.
- (5) For fundamental lateral periods, T_a , greater than 2.0 s, use the 2.0 s values obtained in accordance with Note (1). See Clause 4.1.8.11.(2)(b).
- (6) A "coupled" wall is a wall system with coupling beams, where at least 66% of the base overturning moment resisted by the wall system is carried by the axial tension and compression forces resulting from shear in the coupling beams.
- (7) For fundamental lateral periods, T_a , greater than 4.0 s, use the 4.0 s values of $S(T_a)M_v$ obtained by interpolation between 2.0 s and 5.0 s using the value of M_v obtained in accordance with Note (1). See Clause 4.1.8.11.(2)(a).
- (8) For fundamental lateral periods, T_a , greater than 4.0 s, use the 4.0 s values of J obtained by interpolation between 2.0 s and 5.0 s using the value of J obtained in accordance with Note (1). See Clause 4.1.8.11.(2)(a).

8) The structure shall be designed to resist overturning effects caused by the earthquake forces determined in Sentence (7) and the overturning moment at level x, M_x , shall be determined using the following equation:

$$M_x = J_x \sum_{i=x}^n F_i (h_i - h_x)$$

where

$$J_x = 1.0 \text{ for } h_x \geq 0.6h_n, \text{ and}$$

$$J_x = J + (1 - J)(h_x / 0.6h_n) \text{ for } h_x < 0.6h_n$$

where

J = base overturning moment reduction factor conforming to Table 4.1.8.11.

9) Torsional effects that are concurrent with the effects of the forces mentioned in Sentence (7) and are caused by the simultaneous actions of the following torsional moments shall be considered in the design of the structure according to Sentence (11):

- a) torsional moments introduced by eccentricity between the centres of mass and resistance and their dynamic amplification, and
- b) torsional moments due to accidental eccentricities.

10) Torsional sensitivity shall be determined by calculating the ratio B_x for each level x according to the following equation for each orthogonal direction determined independently:

$$B_x = \delta_{\max} / \delta_{\text{ave}}$$

where

- B = maximum of all values of B_x in both orthogonal directions, except that the B_x for one-storey penthouses with a weight less than 10% of the level below need not be considered,
- δ_{\max} = maximum storey displacement at the extreme points of the structure, at level x in the direction of the earthquake induced by the equivalent static forces acting at distances $\pm 0.10 D_{nx}$ from the centres of mass at each floor, and
- δ_{ave} = average of the displacements at the extreme points of the structure at level x produced by the above-mentioned forces.

11) Torsional effects shall be accounted for as follows:

- a) for a *building* with $B \leq 1.7$ or where $I_E F_a S_a(0.2)$ is less than 0.35, by applying torsional moments about a vertical axis at each level throughout the *building*, derived for each of the following load cases considered separately:
 - i) $T_x = F_x(e_x + 0.10 D_{nx})$, and
 - ii) $T_x = F_x(e_x - 0.10 D_{nx})$
 where F_x is the lateral force at each level determined according to Sentence (7) and where each element of the *building* is designed for the most severe effect of the above load cases, or
- b) for a *building* with $B > 1.7$, in cases where $I_E F_a S_a(0.2)$ is equal to or greater than 0.35, by a Dynamic Analysis Procedure as specified in Article 4.1.8.12.

12) Where the fundamental lateral period, T_a , is determined in accordance with Clause (3)(d) and the *building* is constructed with more than 4 storeys of continuous wood construction and has a timber SFRS consisting of shear walls with wood-based panels or of braced or moment-resisting frames as defined in Table 4.1.8.9., the lateral earthquake force, V , as determined in accordance with Sentence (2) shall be multiplied by 1.2 but need not exceed the value determined by using Clause (2)(c). (See Note A-4.1.8.10.(4).)

4.1.8.12. Dynamic Analysis Procedure

1) Except as provided in Articles 4.1.8.19. and 4.1.8.21., the Dynamic Analysis Procedure shall be in accordance with one of the following methods:

- a) Linear Dynamic Analysis by either the Modal Response Spectrum Method or the Numerical Integration Linear Time History Method using a structural model that complies with the requirements of Sentence 4.1.8.3.(8) (See Note A-4.1.8.12.(1)(a).), or
- b) Non-linear Dynamic Analysis, in which case a special study shall be performed. (See Note A-4.1.8.12.(1)(b).)

- 2)** The spectral acceleration values used in the Modal Response Spectrum Method shall be the design spectral acceleration values, $S(T)$, defined in Sentence 4.1.8.4.(9).
- 3)** The ground motion histories used in the Numerical Integration Linear Time History Method shall be compatible with a response spectrum constructed from the design spectral acceleration values, $S(T)$, defined in Sentence 4.1.8.4.(9). (See Note A-4.1.8.12.(3).)
- 4)** The effects of accidental torsional moments acting concurrently with the lateral earthquake forces that cause them shall be accounted for by the following methods:
- the static effects of torsional moments due to $(\pm 0.10 D_{nx})F_x$ at each level x , where F_x is either determined from the elastic dynamic analysis or determined from Sentence 4.1.8.11.(7) multiplied by $R_d R_o / I_E$, shall be combined with the effects determined by dynamic analysis (See Note A-4.1.8.12.(4)(a).), or
 - if B , as defined in Sentence 4.1.8.11.(10), is less than 1.7, it is permitted to use a three-dimensional dynamic analysis with the centres of mass shifted by a distance of $-0.05 D_{nx}$ and $+0.05 D_{nx}$.
- 5)** Except as provided in Sentence (6), the design elastic base shear, V_{ed} , shall be equal to the elastic base shear, V_e , obtained from a Linear Dynamic Analysis.
- 6)** For structures located on sites other than Class F that have an SFRS with R_d equal to or greater than 1.5, the elastic base shear obtained from a Linear Dynamic Analysis may be multiplied by the larger of the following factors to obtain the design elastic base shear, V_{ed} :
- $$\frac{2S(0.2)}{3S(T_a)} \leq 1.0 \text{ and}$$
- $$S(0.5) / S(T_a) \leq 1.0$$
- 7)** The design elastic base shear, V_{ed} , shall be multiplied by the importance factor, I_E , as determined in Article 4.1.8.5., and shall be divided by $R_d R_o$, as determined in Article 4.1.8.9., to obtain the design base shear, V_d .
- 8)** Except as required by Sentence (9) or (12), if the base shear, V_d , obtained in Sentence (7) is less than 80% of the lateral earthquake design force, V , of Article 4.1.8.11., V_d shall be taken as 0.8 V .
- 9)** For irregular structures requiring dynamic analysis in accordance with Article 4.1.8.7., V_d shall be taken as the larger of the V_d determined in Sentence (7) and 100% of V .
- 10)** Except as required by Sentence (11), the values of elastic *storey* shears, *storey* forces, member forces, and deflections obtained from the Linear Dynamic Analysis, including the effect of accidental torsion determined in Sentence (4), shall be multiplied by V_d / V_e to determine their design values, where V_d is the base shear.
- 11)** For the purpose of calculating deflections, it is permitted to use a value for V based on the value for T_a determined in Clause 4.1.8.11.(3)(d) to obtain V_d in Sentences (8) and (9).
- 12)** For *buildings* constructed with more than 4 *storeys* of continuous wood *construction*, having a timber SFRS consisting of shear walls with wood-based panels or braced or moment-resisting frames as defined in Table 4.1.8.9., and whose fundamental lateral period, T_a , is determined in accordance with Clause 4.1.8.11.(3)(d), the design base shear, V_d , shall be taken as the larger value of V_d determined in accordance with Sentence (7) and 100% of V . (See Note A-4.1.8.10.(4).)

4.1.8.13. Deflections and Drift Limits

- 1)** Except as provided in Sentences (5) and (6), lateral deflections of a structure shall be calculated in accordance with the loads and requirements defined in this Subsection.
- 2)** Lateral deflections obtained from a linear elastic analysis using the methods given in Articles 4.1.8.11. and 4.1.8.12. and incorporating the effects of torsion, including accidental torsional moments, shall be multiplied by $R_d R_o / I_E$ and increased as required in Sentences 4.1.8.10.(6) and 4.1.8.16.(1) to give realistic values of anticipated deflections.
- 3)** Based on the lateral deflections calculated in Sentences (2), (5) and (6), the largest interstorey deflection at any level shall be limited to 0.01 h_s for *post-disaster buildings*, 0.02 h_s for High Importance Category *buildings*, and 0.025 h_s for all other *buildings*.
- 4)** The deflections calculated in Sentence (2) shall be used to account for sway effects as required by Sentence 4.1.3.2.(12). (See Note A-4.1.8.13.(4).)
- 5)** The lateral deflections of a seismically isolated structure shall be calculated in accordance with

Article 4.1.8.20.

6) The lateral deflections of a structure with supplemental energy dissipation shall be calculated in accordance with Article 4.1.8.22.

4.1.8.14. Structural Separation

1) Adjacent structures shall either be separated by the square root of the sum of the squares of their individual deflections calculated in Sentence 4.1.8.13.(2), or shall be connected to each other.

2) The method of connection required in Sentence (1) shall take into account the mass, stiffness, strength, ductility and anticipated motion of the connected *buildings* and the character of the connection.

3) Rigidly connected *buildings* shall be assumed to have the lowest R_dR_o value of the *buildings* connected.

4) *Buildings* with non-rigid or energy-dissipating connections require special studies.

4.1.8.15. Design Provisions

1) Except as provided in Sentences (2) and (3), diaphragms, collectors, chords, struts and connections shall be designed so as not to yield, and the design shall account for the shape of the diaphragm, including openings, and for the forces generated in the diaphragm due to the following cases, whichever one governs (See Note A-4.1.8.15.(1).):

- a) forces due to loads determined in Article 4.1.8.11. or 4.1.8.12. applied to the diaphragm are increased to reflect the lateral load capacity of the SFRS, plus forces in the diaphragm due to the transfer of forces between elements of the SFRS associated with the lateral load capacity of such elements and accounting for discontinuities and changes in stiffness in these elements, or
- b) a minimum force corresponding to the design-based shear divided by N for the diaphragm at level x.

2) Steel deck roof diaphragms in *buildings* of less than 4 storeys or wood diaphragms that are designed and detailed according to the applicable referenced design standards to exhibit ductile behaviour shall meet the requirements of Sentence (1), except that they may yield and the forces shall be

- a) for wood diaphragms acting in combination with vertical wood shear walls, equal to the lateral earthquake design force,
- b) for wood diaphragms acting in combination with other SFRS, not less than the force corresponding to $R_dR_o = 2.0$, and
- c) for steel deck roof diaphragms, not less than the force corresponding to $R_dR_o = 2.0$.

3) Where diaphragms are designed in accordance with Sentence (2), the struts shall be designed in accordance with Clause 4.1.8.15.(1)(a) and the collectors, chords and connections between the diaphragms and the vertical elements of the SFRS shall be designed for forces corresponding to the capacity of the diaphragms in accordance with the applicable CSA standards. (See Note A-4.1.8.15.(3).)

4) For single-storey *buildings* with steel deck or wood roof diaphragms designed with a value of R_d greater than 1.5 and where the calculated maximum relative deflection, Δ_D , of the diaphragm under lateral loads exceeds 50% of the average storey drift, Δ_B , of the adjoining vertical elements of the SFRS, dynamic magnification of the inelastic response due to the in-plane diaphragm deformations shall be accounted for in the design as follows:

- a) the vertical elements of the SFRS shall be designed and detailed to any one of the following:
 - i) to accommodate the anticipated magnified lateral deformations taken as $R_oR_d(\Delta_B + \Delta_D) - R_o\Delta_D$,
 - ii) to resist the forces magnified by $R_d(1 + \Delta_D/\Delta_B)/(R_d + \Delta_D/\Delta_B)$, or
 - iii) by a special study, and
- b) the roof diaphragm and chords shall be designed for in-plane shears and moments determined while taking into consideration the inelastic higher mode response of the structure.

(See Note A-4.1.8.15.(4).)

5) In cases where $I_EF_aS_a(0.2)$ is equal to or greater than 0.35, the elements supporting any discontinuous wall, column or braced frame shall be designed for the lateral load capacity of the components of the SFRS they support. (See Note A-4.1.8.15.(5).)

6) Where structures have vertical variations of R_dR_o satisfying Sentence 4.1.8.9.(4), the elements of the SFRS below the level where the change in R_dR_o occurs shall be designed for the forces associated with the lateral load capacity of the SFRS above that level. (See Note A-4.1.8.15.(6).)

7) Where earthquake effects can produce forces in a column or wall due to lateral loading along both orthogonal axes, account shall be taken of the effects of potential concurrent yielding of other elements framing into the column or wall from all directions at the level under consideration and as appropriate at other levels. (See Note A-4.1.8.15.(7).)

8) The design forces associated with the lateral capacity of the SFRS need not exceed the forces determined in accordance with Sentence 4.1.8.7.(1) with $R_d R_o$ taken as 1.0, unless otherwise provided by the applicable referenced design standards for elements, in which case the design forces associated with the lateral capacity of the SFRS need not exceed the forces determined in accordance with Sentence 4.1.8.7.(1) with $R_d R_o$ taken as less than or equal to 1.3. (See Note A-4.1.8.15.(8).)

9) *Foundations* need not be designed to resist the lateral load overturning capacity of the SFRS, provided the design and the R_d and R_o for the type of SFRS used conform to Table 4.1.8.9. and that the *foundation* is designed in accordance with Sentence 4.1.8.16.(4).

10) *Foundation* displacements and rotations shall be considered as required by Sentence 4.1.8.16.(1).

4.1.8.16. Foundation Provisions

1) The increased displacements of the structure resulting from *foundation* movement shall be shown to be within acceptable limits for both the SFRS and the structural framing elements not considered to be part of the SFRS. (See Note A-4.1.8.16.(1).)

2) Except as provided in Sentences (3) and (4), *foundations* shall be designed to have factored shear and overturning resistances greater than the lateral load capacity of the SFRS. (See Note A-4.1.8.16.(2).)

3) The shear and overturning resistances of the *foundation* determined using a bearing stress equal to 1.5 times the factored bearing strength of the *soil* or *rock* and all other resistances equal to 1.3 times the factored resistances need not exceed the design forces determined in Sentence 4.1.8.7.(1) using $R_d R_o = 1.0$, except that the factor of 1.3 shall not apply to the portion of the resistance to uplift or overturning resulting from gravity loads.

4) A *foundation* is permitted to have a factored overturning resistance less than the lateral load overturning capacity of the supported SFRS, provided the following requirements are met:

- a) neither the *foundation* nor the supported SFRS are constrained against rotation, and
- b) the design overturning moment of the *foundation* is
 - i) not less than 75% of the overturning capacity of the supported SFRS, and
 - ii) not less than that determined in Sentence 4.1.8.7.(1) using $R_d R_o = 2.0$.

(See Note A-4.1.8.16.(4).)

5) The design of *foundations* shall be such that they are capable of transferring earthquake loads and effects between the building and the ground without exceeding the capacities of the *soil* and *rock*.

6) In cases where $I_E F_a S_a(0.2)$ is equal to or greater than 0.35, the following requirements shall be satisfied:

- a) *piles* or *pile caps*, drilled piers, and *caissons* shall be interconnected by continuous ties in not less than two directions (See Note A-4.1.8.16.(6)(a).),
- b) *piles*, drilled piers, and *caissons* shall be embedded a minimum of 100 mm into the *pile cap* or structure, and
- c) *piles*, drilled piers, and *caissons*, other than wood *piles*, shall be connected to the *pile cap* or structure for a minimum tension force equal to 0.15 times the factored compression load on the *pile*.

7) At sites where $I_E F_a S_a(0.2)$ is equal to or greater than 0.35, *basement* walls shall be designed to resist earthquake lateral pressures from backfill or natural ground. (See Note A-4.1.8.16.(7).)

8) At sites where $I_E F_a S_a(0.2)$ is greater than 0.75, the following requirements shall be satisfied:

- a) *piles*, drilled piers, or *caissons* shall be designed and detailed to accommodate cyclic inelastic behaviour when the design moment in the element due to earthquake effects is greater than 75% of its moment capacity (See Note A-4.1.8.16.(8)(a).), and
- b) spread footings founded on *soil* defined as Site Class E or F shall be interconnected by continuous ties in not less than two directions.

9) Each segment of a tie between elements that is required by Clauses (6)(a) or (8)(b) shall be designed to carry by tension or compression a horizontal force at least equal to the greatest factored *pile cap* or column vertical load in the elements it connects, multiplied by a factor of 0.10 $I_E F_a S_a(0.2)$, unless it can be demonstrated that equivalent restraints can be provided by other means. (See Note A-4.1.8.16.(9).)

10) The potential for liquefaction of the *soil* and its consequences, such as significant ground displacement and loss of *soil* strength and stiffness, shall be evaluated based on the ground motion parameters referenced in Subsection 1.1.3., as modified by Article 4.1.8.4., and shall be taken into account in the design of the structure and its *foundations*. (See Note A-4.1.8.16.(10).)

4.1.8.17. Site Stability

1) The potential for slope instability and its consequences, such as slope displacement, shall be evaluated based on site-specific material properties and ground motion parameters referenced in Subsection 1.1.3., as modified by Article 4.1.8.4., and shall be taken into account in the design of the structure and its *foundations*. (See Note A-4.1.8.17.(1).)

4.1.8.18. Elements of Structures, Non-structural Components and Equipment

(See Note A-4.1.8.18.)

1) Except as provided in Sentences (2), (7) and (16), elements and components of *buildings* described in Table 4.1.8.18. and their connections to the structure shall be designed to accommodate the *building* deflections calculated in accordance with Article 4.1.8.13. and the element or component deflections calculated in accordance with Sentence (9), and shall be designed for a lateral force, V_p , distributed according to the distribution of mass:

$$V_p = 0.3 F_a S_a (0.2) I_E S_p W_p$$

where

F_a = as defined in Sentence 4.1.8.4.(7),

$S_a(0.2)$ = spectral response acceleration value at 0.2 s, as defined in Sentence 4.1.8.4.(1),

I_E = importance factor for the *building*, as defined in Article 4.1.8.5.,

S_p = $C_p A_r A_x / R_p$ (the maximum value of S_p shall be taken as 4.0 and the minimum value of S_p shall be taken as 0.7), where

C_p = element or component factor from Table 4.1.8.18.,

A_r = element or component force amplification factor from Table 4.1.8.18.,

A_x = height factor ($1 + 2 h_x / h_n$),

R_p = element or component response modification factor from Table 4.1.8.18., and

W_p = weight of the component or element.

Table 4.1.8.18.
Elements of Structures and Non-structural Components and Equipment⁽¹⁾
Forming Part of Sentences 4.1.8.18.(1), (2), (3), (6) and (7)

Category	Part or Portion of <i>Building</i>	C_p	A_r	R_p
1	All exterior and interior walls except those in Category 2 or 3	1.00	1.00	2.50
2	Cantilever parapet and other cantilever walls except retaining walls	1.00	2.50	2.50
3	Exterior and interior ornamentations and appendages	1.00	2.50	2.50
4	Floors and roofs acting as diaphragms ⁽²⁾	–	–	–
5	Towers, <i>chimneys</i> , smokestacks and penthouses when connected to or forming part of a <i>building</i>	1.00	2.50	2.50
6	Horizontally cantilevered floors, balconies, beams, etc.	1.00	1.00	2.50
7	Suspended ceilings, light fixtures and other attachments to ceilings with independent vertical support	1.00	1.00	2.50
8	Masonry veneer connections	1.00	1.00	1.50
9	Access floors	1.00	1.00	2.50
10	Masonry or concrete fences more than 1.8 m tall	1.00	1.00	2.50
11	Machinery, fixtures, equipment and tanks (including contents)			
	that are rigid and rigidly connected	1.00	1.00	1.25
	that are flexible or flexibly connected	1.00	2.50	2.50

Table 4.1.8.18. (continued)
Elements of Structures and Non-structural Components and Equipment⁽¹⁾
 Forming Part of Sentences 4.1.8.18.(1), (2), (3), (6) and (7)

Category	Part or Portion of Building	C _p	A _r	R _p
12	Machinery, fixtures, equipment and tanks (including contents) containing toxic or explosive materials, materials having a flash point below 38°C or firefighting fluids that are rigid and rigidly connected	1.50	1.00	1.25
	that are flexible or flexibly connected	1.50	2.50	2.50
13	Flat bottom tanks (including contents) attached directly to a floor at or below <i>grade</i> within a <i>building</i>	0.70	1.00	2.50
14	Flat bottom tanks (including contents) attached directly to a floor at or below <i>grade</i> within a <i>building</i> containing toxic or explosive materials, materials having a <i>flash point</i> below 38°C or firefighting fluids	1.00	1.00	2.50
15	Pipes, ducts (including contents)	1.00	1.00	3.00
16	Pipes, ducts (including contents) containing toxic or explosive materials	1.50	1.00	3.00
17	Electrical cable trays, bus ducts, conduits	1.00	2.50	5.00
18	Rigid components with ductile material and connections	1.00	1.00	2.50
19	Rigid components with non-ductile material or connections	1.00	1.00	1.00
20	Flexible components with ductile material and connections	1.00	2.50	2.50
21	Flexible components with non-ductile material or connections	1.00	2.50	1.00
22	Elevators and escalators ⁽³⁾ machinery and equipment elevator rails	as per category 11		
		1.00	1.00	2.50
23	Floor-mounted steel pallet storage racks ⁽⁴⁾	1.00	2.50	2.50
24	Floor-mounted steel pallet storage racks on which are stored toxic or explosive materials or materials having a <i>flash point</i> below 38°C ⁽⁴⁾ .	1.50	2.50	2.50

Notes to Table 4.1.8.18.:

(1) See Note A-Table 4.1.8.18.

(2) See Sentence (8).

(3) See also the Elevating Devices Safety Regulation

(4) See Sentence (13) and Note A-Table 4.1.8.18.

2) For *buildings* other than *post-disaster buildings*, seismically isolated *buildings*, and *buildings* with supplemental energy dissipation systems, where $I_E F_a S_a(0.2)$ is less than 0.35, the requirements of Sentence (1) need not apply to Categories 6 through 22 of Table 4.1.8.18.

3) For the purpose of applying Sentence (1) for Categories 11 and 12 of Table 4.1.8.18., elements or components shall be assumed to be flexible or flexibly connected unless it can be shown that the fundamental period of the element or component and its connection is less than or equal to 0.06 s, in which case the element or component is classified as being rigid or rigidly connected.

4) The weight of access floors shall include the *dead load* of the access floor and the weight of permanent equipment, which shall not be taken as less than 25% of the floor *live load*.

5) When the mass of a tank plus its contents or the mass of a flexible or flexibly connected piece of machinery, fixture or equipment is greater than 10% of the mass of the supporting floor, the lateral forces shall be determined by rational analysis.

6) Forces shall be applied in the horizontal direction that results in the most critical loading for design, except for Category 6 of Table 4.1.8.18., where the forces shall be applied up and down vertically.

7) Connections to the structure of elements and components listed in Table 4.1.8.18. shall be designed to support the component or element for gravity loads, shall conform to the requirements of Sentence (1), and shall also satisfy these additional requirements:

- a) friction due to gravity loads shall not be considered to provide resistance to seismic forces,

- b) R_p for non-ductile connections, such as adhesives or power-actuated fasteners, shall be taken as 1.0,
- c) R_p for anchorage using shallow expansion, chemical, epoxy or cast-in-place anchors shall be 1.5, where shallow anchors are those with a ratio of embedment length to diameter of less than 8,
- d) power-actuated fasteners and drop-in anchors shall not be used for tension loads,
- e) connections for non-structural elements or components of Category 1, 2 or 3 of Table 4.1.8.18. attached to the side of a *building* and above the first level above *grade* shall satisfy the following requirements:
- for connections where the body of the connection is ductile, the body shall be designed for values of C_p , A_r and R_p given in Table 4.1.8.18., and all of the other parts of the connection, such as anchors, welds, bolts and inserts, shall be capable of developing 2.0 times the nominal yield resistance of the body of the connection, and
 - connections where the body of the connection is not ductile shall be designed for values of $C_p = 2.0$, $R_p = 1.0$ and A_r given in Table 4.1.8.18., and
- f) a ductile connection is one where the body of the connection is capable of dissipating energy through cyclic inelastic behaviour.
- 8)** Floors and roofs acting as diaphragms shall satisfy the requirements for diaphragms stated in Article 4.1.8.15.
- 9)** Lateral deflections of elements or components shall be based on the loads defined in Sentence (1) and lateral deflections obtained from an elastic analysis shall be multiplied by R_p/I_E to give realistic values of the anticipated deflections.
- 10)** The elements or components shall be designed so as not to transfer to the structure any forces unaccounted for in the design, and rigid elements such as walls or panels shall satisfy the requirements of Sentence 4.1.8.3.(6).
- 11)** Seismic restraint for suspended equipment, pipes, ducts, electrical cable trays, etc. shall be designed to meet the force and displacement requirements of this Article and be constructed in a manner that will not subject hanger rods to bending.
- 12)** Isolated suspended equipment and components, such as pendent lights, may be designed as a pendulum system provided that adequate chains or cables capable of supporting 2.0 times the weight of the suspended component are provided and the deflection requirements of Sentence (10) are satisfied.
- 13)** Free-standing steel pallet storage racks are permitted to be designed to resist earthquake effects using rational analysis, provided the design achieves the minimum performance level required by Subsection 4.1.8. (See Note A-4.1.8.18.(13).)
- 14)** Except as provided in Sentence (15), the relative displacement of glass in glazing systems, D_{fallout} , shall be equal to the greater of
- $D_{\text{fallout}} \geq 1.25I_E D_p$, where
 D_{fallout} = relative displacement at which glass fallout occurs, and
 D_p = relative earthquake displacement that the component must be designed to accommodate, calculated in accordance with Article 4.1.8.13. and applied over the height of the glass component, or
 - 13 mm.
- (See Note A-4.1.8.18.(14) and (15)(c).)
- 15)** Glass need not comply with Sentence (14), provided at least one of the following conditions is met:
- $I_E F_a S_a(0.2) < 0.35$,
 - the glass has sufficient clearance from its frame such that $D_{\text{clear}} \geq 1.25 D_p$ calculated as follows:

$$D_{\text{clear}} = 2C_1 (1 + h_p C_2 / (b_p C_1))$$
- where
- D_{clear} = relative horizontal displacement measured over the height of the glass panel, which causes initial glass-to-frame contact,
 - C_1 = average of the clearances on both sides between the vertical glass edges and the frame,
 - h_p = height of the rectangular glass panel,
 - C_2 = averages of the top and bottom clearances between the horizontal glass edges and the frame, and
 - b_p = width of the rectangular glass panel,
- c) the glass is fully tempered, monolithic, installed in a non-*post-disaster building*, and no part of the glass is

- located more than 3 m above a walking surface (See Note A-4.1.8.18.(14) and (15)(c).), or
- d) the glass is annealed or heat-strengthened laminated glass in a single thickness with an interlayer no less than 0.76 mm and captured mechanically in a wall system glazing pocket with the perimeter secured to the frame by a wet, glazed, gunable, curing, elastomeric sealant perimeter bead of 13 mm minimum glass contact width.
- 16)** For structures with supplemental energy dissipation, the following criteria shall apply:
- a) the value of $S_a(0.2)$ used in Sentence (1) shall be determined from the mean 5% damped floor spectral acceleration values at 0.2 s by averaging the individual 5% damped floor spectra at the base of the structure determined using Non-Linear Dynamic Analysis, and
- b) the value of F_a used in Sentence (1) shall be 1.

4.1.8.19. Seismic Isolation

1) For the purposes of this Article and Article 4.1.8.20., the following terms shall have the meanings stated herein:

- a) “seismic isolation” is an alternative seismic design concept that consists of installing an isolation system with low horizontal stiffness, thereby substantially increasing the fundamental period of the structure;
- b) “isolation system” is a collection of structural elements at the level of the isolation interface that includes all individual isolator units, all structural elements that transfer force between elements of the isolation system, all connections to other structural elements, and may also include a wind-restraint system, energy-dissipation devices, and a displacement restraint system;
- c) “seismically isolated structure” includes the upper portion of the structure above the isolation system, the isolation system, and the portion of the structure below the isolation system;
- d) “isolator unit” is a structural element of the isolation system that permits large lateral deformations under lateral earthquake design forces and is characterized by vertical-load-carrying capability combined with increased horizontal flexibility and high vertical stiffness, energy dissipation (hysteretic or viscous), self-centering capability, and lateral restraint (sufficient elastic stiffness) under non-seismic service lateral loads;
- e) “isolation interface” is the boundary between the isolated upper portion of the structure above the isolation system and the lower portion of the structure below the isolation system; and
- f) “wind-restraint system” is the collection of structural elements of the isolation system that provides restraint of the seismically isolated structure for wind loads and is permitted to be either an integral part of the isolator units or a separate device.

2) Every seismically isolated structure and every portion thereof shall be analyzed and designed in accordance with

- a) the loads and requirements prescribed in this Article and Article 4.1.8.20.,
- b) other applicable requirements of this Subsection, and
- c) appropriate engineering principles and current engineering practice.

(See Note A-4.1.8.19.(2).)

3) For the analysis and modeling of the seismically isolated structure, the following criteria shall apply:

- a) a three-dimensional Non-linear Dynamic Analysis of the structure shall be performed in accordance with Article 4.1.8.12. (See Note A-4.1.8.19.(3)(a).),
- b) unless verified from rational analysis, the inherent equivalent viscous damping – excluding the hysteretic damping provided by the isolation system or supplemental energy dissipation devices – used in the analysis shall not be taken as more than 2.5% of the critical damping at the significant modes of vibration,
- c) all individual isolator units shall be modeled with sufficient detail to account for their non-linear force-deformation characteristics, including effects of the relevant loads, and with consideration of variations in material properties over the design life of the structure, and
- d) except for elements of the isolation system, other components of the seismically isolated structure shall be modeled using elastic material properties in accordance with Sentence 4.1.8.3.(8).

4) The ground motion histories used in Sentence (3) shall be

- a) appropriately selected and scaled following good engineering practice,
- b) compatible with

- i) a response spectrum derived from the design spectral acceleration values, $S(T)$, defined in Sentence 4.1.8.4.(9) for ground conditions of Site Classes A, B and C, and
- ii) a 5% damped response spectrum based on a site-specific evaluation for ground conditions of Site Classes D, E and F, and
- c) amplitude-scaled in an appropriate manner over the period range of $0.2 T_1$ to $1.5 T_1$, where T_1 is the period of the isolated structure determined using the post-yield stiffness of the isolation system in the horizontal direction under consideration, or the period specified in Sentence 4.1.8.20.(1) if the post-yield stiffness of the isolation system is not well defined.

(See Note A-4.1.8.19.(4).)

4.1.8.20. Seismic Isolation Design Provisions

- 1) The period of the isolated structure, determined using the post-yield stiffness of the isolation system in the horizontal direction under consideration, shall be greater than three times the period of the structure above the isolation interface calculated as a fixed base.
- 2) The isolation system shall be configured to produce a restoring force such that the lateral force at the TDD at the centre of mass of the isolated structure above the isolation interface is at least $0.025W_b$ greater than the lateral force at 50% of the TDD at the same location, in each horizontal direction, where W_b is the portion of W above the isolation interface.
- 3) The values of *storey* shears, *storey* forces, member forces, and deflections used in the design of all structural framing elements and components of the isolation system shall be obtained from analysis conforming to Sentence 4.1.8.19.(3) using one of the following values, whichever produces the most critical effect:
 - a) mean plus I_E times the standard deviation of results of all Non-linear Dynamic Analyses, or
 - b) $\sqrt{I_E}$ times the mean of the results of all Non-linear Dynamic Analyses.
- 4) The force-deformation and damping characteristics of the isolation system used in the analysis and design of the seismically isolated structures shall be validated by testing at least two full-size specimens of each predominant type and size of isolator unit of the isolation system, which shall include
 - a) the individual isolator units,
 - b) separate supplemental damping devices, if used, and
 - c) separate sacrificial wind-restraint systems, if used.
- 5) The force-deformation characteristics and damping value of a representative sample of the isolator units installed in the *building* shall be validated by tests prior to their installation.
- 6) A diaphragm or horizontal structural elements shall provide continuity immediately above the isolation interface to transmit forces due to non-uniform ground motions from one part of the structure to another.
- 7) All structural framing elements shall be designed for the forces described in Sentence (3) with $R_d R_o = 1.0$, except
 - a) for structures with $I_E < 1.5$, all SFRS shall be detailed in accordance with the requirements for $R_d \geq 1.5$ and the applicable referenced design standards, and
 - b) for structures with $I_E = 1.5$, all SFRS shall be detailed in accordance with the requirements for $R_d \geq 2.0$ and the applicable referenced design standards.
- 8) The height restrictions noted in Table 4.1.8.9. need not apply to seismically isolated structures.
- 9) All isolator units shall be
 - a) designed for the forces described in Sentence (3), and
 - b) able to accommodate the TDD determined at the specific location of each isolator unit.
- 10) The isolation system, including a separate wind-restraint system if used, shall limit lateral displacement due to wind loads across the isolation interface to a value equal to that required for the least *storey* height in accordance with Sentence 4.1.3.5.(3).

4.1.8.21. Supplemental Energy Dissipation

- 1) For the purposes of this Article and Article 4.1.8.22., the following terms shall have the meanings stated herein:

- a) “supplemental energy dissipation device” is a dedicated structural element of the supplemental energy dissipation system that dissipates energy due to relative motion of each of its ends or by alternative means, and includes all pins, bolts, gusset plates, brace extensions and other components required to connect it to the other elements of the structure; a device may be classified as either displacement-dependent or velocity-dependent, or a combination thereof, and may be configured to act in either a linear or non-linear manner, and
 - b) “supplemental energy dissipation system” is a collection of energy dissipation devices installed in a structure that supplement the energy dissipation of the SFRS.
- 2)** Every structure with a supplemental energy dissipation system and every portion thereof shall be designed and constructed in accordance with
- a) the loads and requirements prescribed in this Article and Article 4.1.8.22.,
 - b) other applicable requirements of this Subsection, and
 - c) appropriate engineering principles and current engineering practice.

(See Note A-4.1.8.21.(2).)

3) Where supplemental energy dissipation devices are used across the isolation interface of a seismically isolated structure, displacements, velocities, and accelerations shall be determined in accordance with Article 4.1.8.20.

4) For the analysis and modeling of structures with supplemental energy dissipation devices, the following criteria shall apply:

- a) a three-dimensional Non-linear Dynamic Analysis of the structure shall be performed in accordance with Article 4.1.8.12. (See Note A-4.1.8.21.(4)(a).),
 - b) for SFRS with $R_d > 1.0$, the non-linear hysteretic behaviour of the SFRS shall be explicitly – with sufficient detail – accounted for in the modeling and analysis of the structure,
 - c) unless verified from rational analysis, the inherent equivalent viscous damping – excluding the damping provided by the supplemental energy dissipation devices – used in the analysis shall not be taken as more than 2.5% of the critical damping at the significant modes of vibration,
 - d) all supplemental energy dissipation devices shall be modeled with sufficient detail to account for their non-linear force deformation characteristics, including effects of the relevant loads, and with consideration of variations in their properties over the design life of the structure, and
 - e) except for the SFRS and elements of the supplemental energy dissipation system, other components of the structure shall be modeled using elastic material properties in accordance with Sentence 4.1.8.3.(8).
- 5)** The ground motion histories used in Sentence (4) shall be
- a) appropriately selected and scaled following good engineering practice,
 - b) compatible with a 5% damped response spectrum derived from the design spectral acceleration values, $S(T)$, defined in Sentence 4.1.8.4.(9), and
 - c) amplitude-scaled in an appropriate manner over the period range of $0.2 T_1$ to $1.5 T_1$, where T_1 is the fundamental lateral period of the structure with the supplemental energy dissipation system.

(See Note A-4.1.8.21.(5).)

4.1.8.22. Supplemental Energy Dissipation Design Considerations

1) The values of *storey* shears, *storey* forces, member forces, and deflections for the design of all structural framing elements and all supplemental energy dissipation devices shall be obtained from analysis conforming to Sentence 4.1.8.21.(4) using one of the following values, whichever produces the most critical effect:

- a) mean plus I_E times the standard deviation of the results of all Non-linear Dynamic Analyses, or
- b) $\sqrt{I_E}$ times the mean of the results of all Non-linear Dynamic Analyses.

2) The largest interstorey deflection at any level of the structure as determined in accordance with Sentence (1) shall conform to the limits stated in Sentence 4.1.8.13.(3).

3) The force-deformation and force-velocity characteristics of the supplemental energy dissipation devices used in the analysis and design of structures with supplemental energy dissipation systems shall be validated by testing at least two full-size specimens of each type of supplementary energy dissipation device.

4) The force-deformation and force-velocity characteristics and damping values of a representative sample of the supplemental energy dissipation devices installed in the *building* shall be validated by tests prior to their installation.

- 5)** Elements of the supplemental energy dissipation system, except the supplemental energy dissipation devices themselves, shall be designed to remain elastic for the design loads.
- 6)** All structural framing elements shall be designed
- a) for an SFRS with $R_d = 1.0$, using the forces referred to in Sentence (1) with $R_d R_o = 1.0$, except that the SFRS shall be detailed in accordance with the requirements for $R_d \geq 1.5$ and the applicable referenced design standards, or
 - b) for an SFRS with $R_d > 1.0$, using the forces referred to in Sentence (1) with $R_d R_o = 1.0$, except that the SFRS shall be detailed in accordance with the requirements for the selected R_d and the applicable referenced design standards.
- 7)** Supplemental energy dissipation devices and other components of the supplemental energy dissipation system shall be designed in accordance with Sentence (1) with consideration of the following:
- a) low-cycle, large-displacement degradation due to seismic loads,
 - b) high-cycle, small-displacement degradation due to wind, thermal, or other cyclic loads,
 - c) forces or displacements due to gravity loads,
 - d) adhesion of device parts due to corrosion or abrasion, biodegradation, moisture, or chemical exposure,
 - e) exposure to environmental conditions, including, but not limited to, temperature, humidity, moisture, radiation (e.g., ultraviolet light), and reactive or corrosive substances (e.g., salt water),
 - f) devices subject to failure due to low-cycle fatigue must resist wind forces without slip, movement, or inelastic cycling,
 - g) the range of thermal conditions, device wear, manufacturing tolerances, and other effects that cause device properties to vary during the design life of the device, and
 - h) connection points of devices must provide sufficient articulation to accommodate simultaneous longitudinal, lateral, and vertical displacements of the supplemental energy dissipation system.
- 8)** Means of access for inspection and removal for replacement of all supplemental energy dissipation devices shall be provided.